

SUBMITTAL DATA SHEET

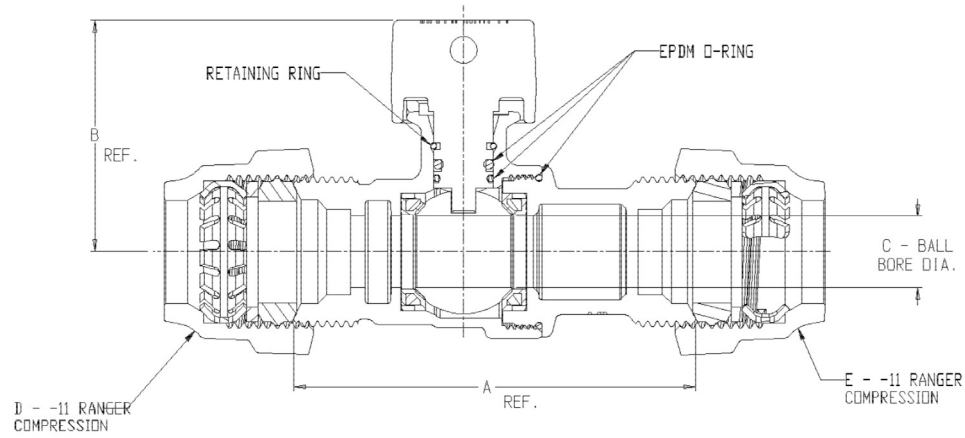

NL Ball Style Curb Stop – 76100-11

-11 Ranger Compression X -11 Ranger Compression



MODEL	SIZE	A	B	C	D	PIPE/TUBE SIZE RANGE (in.)	E	PIPE/TUBE SIZE RANGE (in.)
76100-11	3/4	4.21	2.42	.75	3/4	.871-1.089	3/4	.871-1.089
76100-11	3/4 X 10.12	10.12	2.42	.75	3/4	.871-1.089	3/4	.871-1.089
76100-11	1	4.48	2.64	1.00	1	1.120-1.399	1	1.120-1.399
76100-11	1 X 10.50	10.50	2.64	1.00	1	1.120-1.399	1	1.120-1.399
76100-11	1 1/4	5.59	2.94	1.25	1 1/4	1.370-1.804	1 1/4	1.370-1.804
76100-11	1 1/4 X 11.25	11.25	2.94	1.25	1 1/4	1.370-1.804	1 1/4	1.370-1.804

NOTE: McDONALD RANGER NUTS ARE NOT COMPATIBLE WITH OTHER MANUFACTURERS COMPRESSION NUT SYSTEMS
 McDONALD RANGER NUTS ARE NOT COMPATIBLE WITH OTHER McDONALD COMPRESSION NUT SYSTEMS

SUBMITTAL INFORMATION

- Manufactured in compliance with ANSI/AWWA C800 (latest revision)
- Brass components in contact with potable water conform to ASTM B584, UNS C89833 (latest revision) and identified with “NL”
- Certified to NSF/ANSI 61 and NSF/ANSI 372
- Brass components not in contact with potable water conform to ASTM B62 and ASTM B584, UNS C83600 -85-5-5-5 (latest revision)
- PTFE coated brass ball
- Valve rated for 300 PSIG water pressure, end connections not to exceed rated pipe pressures.
- Blow out proof EPDM port seals
- End piece joint sealed with an EPDM o-ring and thread locker
- Insert stiffeners required on all flexible plastic connections



A.Y. McDonald Mfg. Co.
 4800 Chavenelle Rd
 Dubuque, IA 52002

Toll Free: 1-800-292-2737
sales@aymcdonald.com
aymcdonald.com

A.Y. McDonald considers the information on this assembly drawing correct when published. Item and option availability, including specifications, are subject to change without notice.

Submitted by: