

SUBMITTAL DATA SHEET

Silicon Bronze Strap Saddle - 3816

Ductile Iron/Cement-Asbestos/Cast Iron x FNPT



MODEL	SIZE	A	B	C	D
3816	4 X 3/4	3/4	2.92	1.69	4.74 - 5.40
3816	4 X 1	1	2.92	1.69	4.74 - 5.40
3816	6 X 3/4	3/4	2.92	1.69	6.84 - 7.50
3816	6 X 1	1	2.92	1.69	6.84 - 7.50
3816	8 X 3/4	3/4	2.92	1.69	8.99 - 9.67
3816	8 X 1	1	2.92	1.69	8.99 - 9.67
3816	10 X 3/4	3/4	2.92	1.69	11.04 - 12.12
3816	10 X 1	1	2.92	1.69	11.04 - 12.12
3816	12 X 3/4	3/4	2.92	1.69	13.14 - 14.58
3816	12 X 1	1	2.92	1.69	13.14 - 14.58

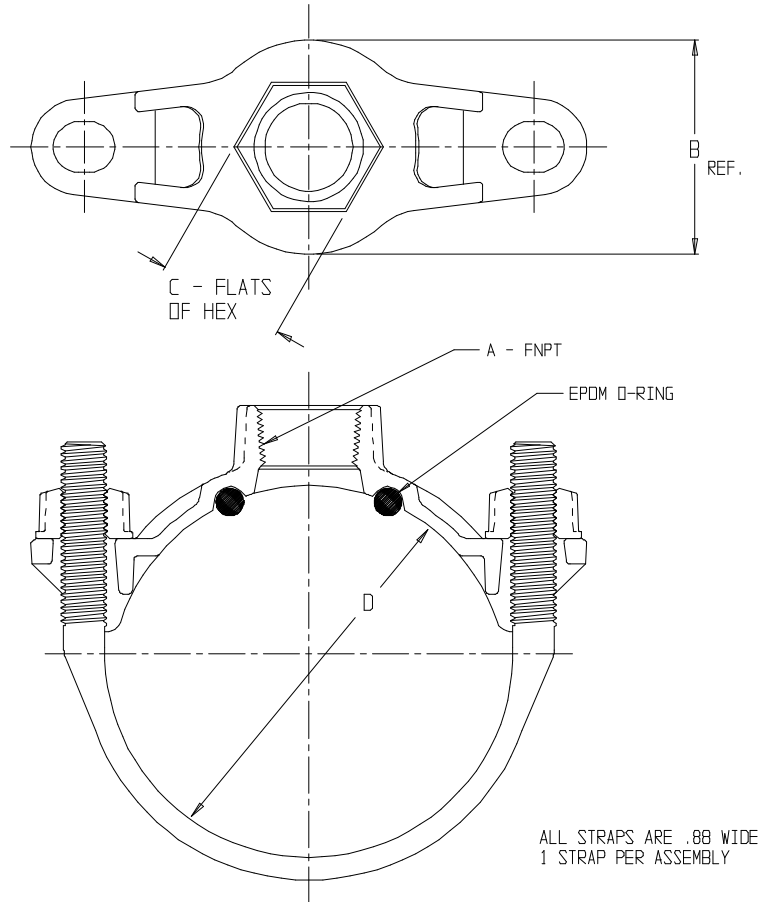

SUBMITTAL INFORMATION

- Manufactured in compliance with ANSI/AWWA C800 (latest revision)
- Brass components conform to ASTM B62 and ASTM B584, UNS C83600 -85-5-5-5 (latest revision)
- Certified to NSF/ANSI 61
- Silicon Bronze strap(s) and cast brass nuts with enlarged washer bearing surface
- EPDM o-ring
- Pipe and tap size, and thread type identified on saddle
- Outlet boss with large wrench flats
- Made in the United States of America



A.Y. McDonald Mfg. CO.
4800 Chavenelle Rd
Dubuque, IA 52002

Toll Free: 1-800-292-2737
sales@aymcdonald.com
aymcdonald.com

A.Y. McDonald considers the information on this assembly drawing correct when published. Item and option availability, including specifications, are subject to change without notice.

Submitted by: