

SUBMITTAL DATA SHEET

Jet Pumps
Convertible | Shallow Well

8300 Series - E-Series



Available in 1/2, 3/4, 1, and 1 1/2 HP, these pumps also offer flows of up to 32 gallons per minute (GPM). The E-Series Jet Pump is designed with a 1 1/4" inlet and 1" outlet while allowing for an easy switch between 115V and 230V.

The High Pressure E-Series Jet Pump is available in 1/2 HP with pressures to 80 PSI and flows up to 11 gallons per minute (GPM).

Models Available

Part No.	Model No.	HP	Volts	Max Amp	Suction	Discharge	Switch	Ship WT. (lbs.)
6156-125	8350	1/2	115 / 230	10.8	1 1/4"	1"	20/40	52
6156-143	8350HP	1/2	115 / 230	10.8	1 1/4"	1"	40/60	52
6156-126	8370	3/4	230 / 115	7.1	1 1/4"	1"	30/50	53
6156-127	8310	1	230 / 115	8.3	1 1/4"	1"	30/50	63
6156-128	8315	1 1/2	230 / 115	10.5	1 1/4"	1"	40/60	65

Factory Voltage Setting listed first in bold type.

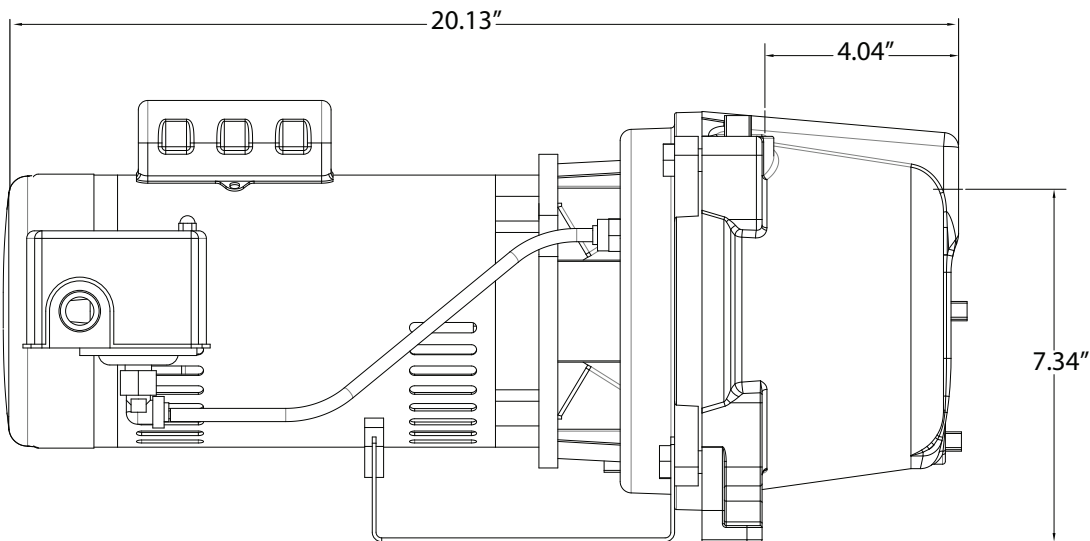

SUBMITTAL INFORMATION

- Up to 32 GPM
- 1" Outlet
- 1 1/4" Inlet
- Reliable, robust, and tested motor
- Easy to switch between 115V & 230V
- 304 Stainless steel motor shaft with wrench flat
- All iron pump housing and seal plate
- 304 Stainless steel insert on plastic impeller
- Stainless steel wear ring between the impeller & diffuser
- Stainless steel bolt hardware connecting pump to motor

NO-LEAD: The weighted average of the wetted surface of this no-lead product contacted by consumable water contains less than one quarter of one percent (0.25%) lead.



A.Y. McDonald Mfg. Co.
4800 Chavenelle Rd
Dubuque, IA 52002

Toll Free: 1-800-292-2737
sales@aymcdonald.com
aymcdonald.com

A.Y. McDonald considers the information on this assembly drawing correct when published. Item and option availability, including specifications, are subject to change without notice.

Submitted by:

SUBMITTAL DATA SHEET

Jet Pumps
 Convertible | Shallow Well
8300 Series - E-Series



Performance

Model No.	HP	Suction Lift - FT.	20	30	40	50	60	Max. Shut off PSI
8350	1/2	5	17.4	12.6	8.0	2.7	-	58
		10	15.8	11.9	6.6	1.6	-	56
		15	12.9	10.9	5.6	0.8	-	52
		20	10.7	9.4	4.4	0.2	-	51
		25	8.5	8.3	3.6	0.1	-	51
8350HP	1/2	5	10.6	10.6	9.3	6.5	3.4	80
		10	9.4	9.	9.2	6.1	3.1	77
		15	8.2	8.1	8.0	5.3	2.3	74
		20	6.6	6.7	6.7	4.6	1.9	73
		25	4.9	5.0	5.0	4.1	0.0	70
8370	3/4	5	-	22.2	17.1	11.1	6.7	73
		10	-	20.0	15.8	10.8	6.0	70
		15	-	16.5	13.8	9.4	3.7	66
		20	-	13.7	10.9	7.5	1.6	62
		25	-	11.2	10.6	6.6	0.4	61
8310	1	5	-	25.9	21.3	13.8	7.0	70
		10	-	23.3	19.0	12.4	6.0	69
		15	-	19.5	17.1	10.1	3.1	66
		20	-	16.3	15.2	9.6	2.2	63
		25	-	13.4	12.9	7.8	0.2	60
8315	1 1/2	5	-	27.2	26.9	21.8	16.0	87
		10	-	24.1	24.0	20.2	15.2	82
		15	-	20.1	20.1	18.7	13.3	80
		20	-	16.7	16.7	15.9	11.4	75
		25	-	14.3	13.9	13.5	11.3	74

NO-LEAD: The weighted average of the wetted surface of this no-lead product contacted by consumable water contains less than one quarter of one percent (0.25%) lead.



A.Y. McDonald Mfg. Co.
 4800 Chavenelle Rd
 Dubuque, IA 52002

Toll Free: 1-800-292-2737
 sales@aymcdonald.com
 aymcdonald.com

A.Y. McDonald considers the information on this assembly drawing correct when published. Item and option availability, including specifications, are subject to change without notice.

Submitted by: