

# SUBMITTAL DATA SHEET

Pump Repair Parts

## DuraMAC™ Booster Repair Parts



See Pumps & Accessories Price List for Limited Warranty details.



### 20 GPM | E-Series Residential

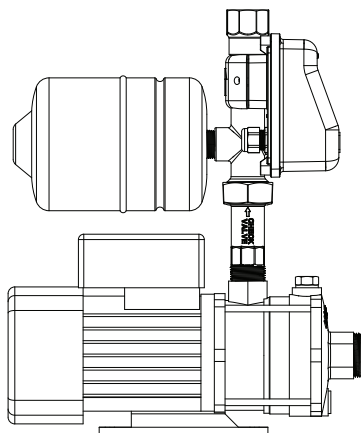

#### 18035R020PC1 / 18035R020PC1SS\*

Part No.	Description
6010-003	17035R020P-1 Pump 120V Pump +35   20 GPM   1/2 HP   120V
6010-103	Control box with cross
6127-382	1/2 Gallon Diaphragm Tank
6010-112	Control Box w/Stainless Steel Cross* 120V
6010-104	Control box

#### 18052R020PC1 / 18052R020PC1SS\*

Part No.	Description
6010-004	17052R020P-1 Pump 120V Pump +52   20 GPM   3/4 HP   120V
6010-103	Control box with cross
6127-382	1/2 Gallon Diaphragm Tank
6010-112	Control Box w/Stainless Steel Cross* 120V
6010-104	Control box

\*SS = Stainless Steel

NO-LEAD: The weighted average of the wetted surface of this no-lead product contacted by consumable water contains less than one quarter of one percent (0.25%) lead.



**A.Y. McDonald Mfg. Co.**  
4800 Chavenelle Rd  
Dubuque, IA 52002

**Toll Free: 1-800-292-2737**  
sales@aymcdonald.com  
aymcdonald.com

A.Y. McDonald considers the information on this assembly drawing correct when published. Item and option availability, including specifications, are subject to change without notice.

**Submitted by:**

# SUBMITTAL DATA SHEET

Pump Repair Parts

## DuraMAC™ Booster Repair Parts



### 20 GPM | Residential

#### 17035R020PC1

Part No.	Description
6010-003	17035R020P-1 Pump 120V, Pump & Motor Assembly Pump +35   20 GPM   1/2 HP   120V
6010-001	Control Box   120V with Tee
6010-009	Control Box   120V (Black box)
6010-026	Transducer   TDL32K   150 PSI   5V
6127-337	Two Gallon Diaphragm Tank
6010-027	Check Valve   1" MNPT x 1" MNPT
6010-554	Seal Kit - (Stage gasket & rotary seal)
6010-032	15000T Booster Tee Assembly
6010-028	Pressure Gauge   0 - 100   2" Dry

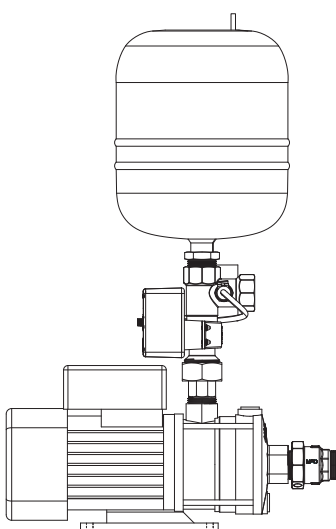

\* T-assembly #6010-032  
for residential and light commercial

#### 17052R020PC1

Part No.	Description
6010-004	17052R020P-1 Pump 120V, Pump & Motor Assembly Pump +52   20 GPM   3/4 HP   120V
6010-001	Control Box   120V with Tee
6010-009	Control Box   120V (Black box)
6010-026	Transducer   TDL32K   150 PSI   5V
6127-337	Two Gallon Diaphragm Tank
6010-027	Check Valve   1" MNPT x 1" MNPT
6010-554	Seal Kit - (Stage gasket & rotary seal)
6010-032	15000T Booster Tee Assembly
6010-028	Pressure Gauge   0 - 100   2" Dry

#### 17070R020PC2

Part No.	Description
6010-005	17070R020P-2 Pump 230V, Pump & Motor Assembly Pump +70   20 GPM   1 HP   230V
6010-002	Control Box   230V with Tee
6010-010	Control Box   230V (Black box)
6010-026	Transducer   TDL32K   150 PSI   5V
6127-337	Two Gallon Diaphragm Tank
6010-027	Check Valve   1" MNPT x 1" MNPT
6010-554	Seal Kit - (Stage gasket & rotary seal)
6010-032	15000T Booster Tee Assembly
6010-028	Pressure Gauge   0 - 100   2" Dry

NO-LEAD: The weighted average of the wetted surface of this no-lead product contacted by consumable water contains less than one quarter of one percent (0.25%) lead.



**A.Y. McDonald Mfg. Co.**  
4800 Chavenelle Rd  
Dubuque, IA 52002

**Toll Free:** 1-800-292-2737  
sales@aymcdonald.com  
aymcdonald.com

A.Y. McDonald considers the information on this assembly drawing correct when published. Item and option availability, including specifications, are subject to change without notice.

**Submitted by:**

# SUBMITTAL DATA SHEET

Pump Repair Parts

## DuraMAC™ Booster Repair Parts



### 35 GPM | Light Commercial

#### 17040C035PC2

Part No.	Description
6010-011	17040C035P-2 Pump 230V, Pump & Motor Assembly Pump +40   35 GPM   1 HP   230V
6010-002	Control Box   230V with Tee
6010-010	Control Box   230V (Black box)
6010-026	Transducer   TDL32K   150 PSI   5V
6127-337	Two Gallon Diaphragm Tank
6010-029	Check   1 1/4" MNPT x 1 1/4" FNPT
6010-554	Seal Kit - (Stage gasket & rotary seal)
6010-032	15000T Booster Tee Assembly
6010-028	Pressure Gauge   0 - 100   2" Dry

#### 17062R035PC2

Part No.	Description
6010-012	17062C035P-2 Pump 230V, Pump & Motor Assembly Pump +62   35 GPM   1 HP   230V
6010-002	Control Box   230V with Tee
6010-010	Control Box   230V (Black box)
6010-026	Transducer   TDL32K   150 PSI   5V
6127-337	Two Gallon Diaphragm Tank
6010-029	Check   1 1/4" MNPT x 1 1/4" FNPT
6010-554	Seal Kit - (Stage gasket & rotary seal)
6010-032	15000T Booster Tee Assembly
6010-028	Pressure Gauge   0 - 100   2" Dry

#### 17078R035PC2

Part No.	Description
6010-013	17078C035P-2 Pump 230V, Pump & Motor Assembly Pump +78   35 GPM   1 1/2 HP   230V
6010-002	Control Box   230V with Tee
6010-010	Control Box   230V (Black box)
6010-026	Transducer   TDL32K   150 PSI   5V
6127-337	Two Gallon Diaphragm Tank
6010-029	Check   1 1/4" MNPT x 1 1/4" FNPT
6010-554	Seal Kit - (Stage gasket & rotary seal)
6010-032	15000T Booster Tee Assembly
6010-028	Pressure Gauge   0 - 100   2" Dry

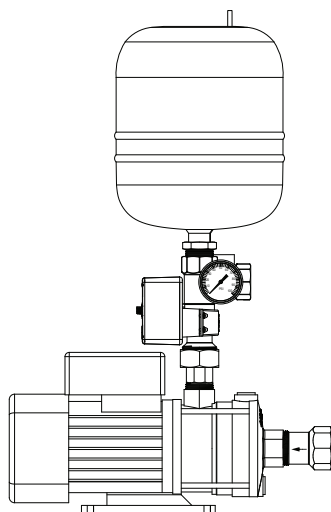

\* T-assembly #6010-032 for residential and light commercial

NO-LEAD: The weighted average of the wetted surface of this no-lead product contacted by consumable water contains less than one quarter of one percent (0.25%) lead.



**A.Y. McDonald Mfg. Co.**  
4800 Chavenelle Rd  
Dubuque, IA 52002

**Toll Free:** 1-800-292-2737  
sales@aymcdonald.com  
aymcdonald.com

A.Y. McDonald considers the information on this assembly drawing correct when published. Item and option availability, including specifications, are subject to change without notice.

**Submitted by:**

# SUBMITTAL DATA SHEET

Pump Repair Parts

## DuraMAC™ Booster Repair Parts



### 70 GPM | Commercial

Modular, Simplex, Duplex

#### 17044C070PC2-M | 17044C070PC2-S | 17044C120PC2-D

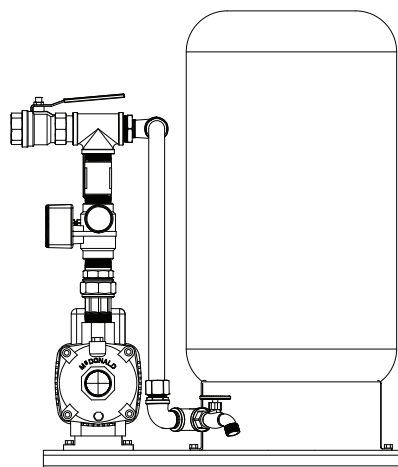

Dual-Mode - Simplex

Part No.	Description
6010-017	17044C070P-2 Pump 230V, Pump & Motor Assembly Pump +44   70 GPM   2 HP   230V
6010-026	Transducer   TDL32K   150 PSI   5V
6011-009	Dual-Mode Control   Repair (Black Box)
6011-012	Paddle Switch
6127-341	16020MV4F - Pressure Tank
6011-011	Pressure Gauge   0 - 100   2 1/2" Liquid filled
6010-555	Seal Kit - (Stage gasket & rotary seal)
5424-401	Ball Valve   1/4" MNPT x 1/4" FNPT (Test Cock)

#### 17060C070PC2-M | 17060C070PC2-S | 17060C120PC2-D

Part No.	Description
6010-018	17060C070P-2 Pump 230V, Pump & Motor Assembly Pump +60   70 GPM   2 HP   230V
6010-026	Transducer   TDL32K   150 PSI   5V
6011-009	Dual-Mode Control   Repair (Black Box)
6011-012	Paddle Switch
6127-341	16020MV4F - Pressure Tank
6011-011	Pressure Gauge   0 - 100   2 1/2" Liquid filled
6010-555	Seal Kit - (Stage gasket & rotary seal)
5424-401	Ball Valve   1/4" MNPT x 1/4" FNPT (Test Cock)

**\*\* Tank Multiplier Applies**

NO-LEAD: The weighted average of the wetted surface of this no-lead product contacted by consumable water contains less than one quarter of one percent (0.25%) lead.



**A.Y. McDonald Mfg. Co.**  
4800 Chavenelle Rd  
Dubuque, IA 52002

**Toll Free: 1-800-292-2737**  
sales@aymcdonald.com  
aymcdonald.com

A.Y. McDonald considers the information on this assembly drawing correct when published. Item and option availability, including specifications, are subject to change without notice.

**Submitted by:**

# SUBMITTAL DATA SHEET

Pump Repair Parts

## DuraMAC™ Booster Repair Parts (IQ1000)



Repair Parts - Vertical Multistage Variable Speed Booster Systems (VSB)

### 3 HP - 10 HP Simplex / Duplex / Triplex

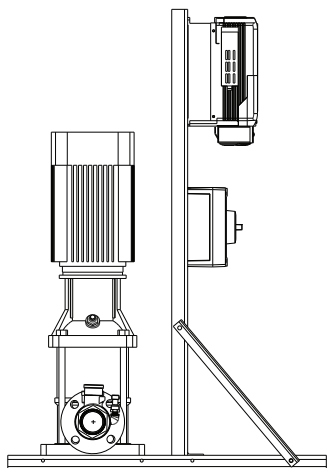

Simplex

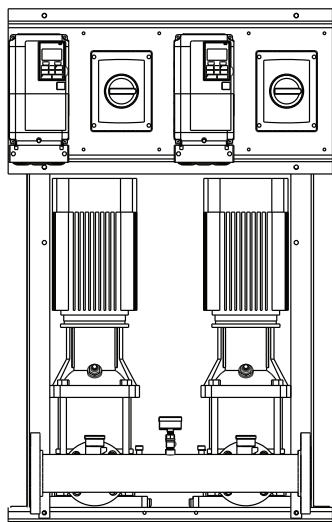

Duplex

Part No.	Description
6012-106	Transducer   4-20mA   150 PSI
6012-107	Transducer   4-20mA   200 PSI
6012-108	Transducer   4-20mA   15 PSI
6012-531	Transducer Cable M12 - 9 ft. long
6012-533	Wafer Check Valve - 2" soft seat
6012-453	Flange Kit Thread 304SS
6012-109	Seal Repair Part SiC / Carbon / EPDM
6012-110	Seal Repair Part (SiC / SiC / EPDM) - Sandy Water
6012-654	Pressure Gauge   200 PSI   Liquid filled
6011-537	Pressure Gauge   100 PSI   Liquid filled

#### IQ 1000 - Contact Factory to insure correct drive programming

6012-575	Yaskawa Drive 3 HP   3 Phase   230V
6012-576	Yaskawa Drive 3 HP   1 Phase   230V Yaskawa Drive 5 HP   3 Phase   230V
6012-577	Yaskawa Drive 7 1/2 HP   3 Phase   230V
6012-578	Yaskawa Drive 5 HP   1 Phase   230V Yaskawa Drive 10 HP   3 Phase   230V
6012-579	Yaskawa Drive 5 HP   3 Phase   460V
6012-580	Yaskawa Drive 7 1/2 HP   3 Phase   460V
6012-581	Yaskawa Drive 10 HP   3 Phase   460V
6012-590	Disconnect - Altech 30 Amp
6012-591	Disconnect - AB 60 Amp
6012-520	Pump end 17062V080
6012-521	Pump end 17084V080
6012-522	Pump end 17104V080
6012-523	Pump end 17150V080
6012-524	Pump end 17142V120
6012-525	Pump end 17060V140
6012-526	Pump end 17088V140
6012-528	Pump end 17056V120
6012-547	Motor TEFC - 3 HP Energy Eff 182TC
6012-548	Motor TEFC - 5 HP Energy Eff 184TC
6012-549	Motor TEFC - 7 HP Energy Eff 213TC
6012-550	Motor TEFC - 10 HP Energy Eff 215TC
6012-551	Motor TEFC - 15 HP Energy Eff 215TC

### Simplex / Duplex Accessories

\*Contact factory for Triplex Accessories

6012-100	17200EJ 3" Flanged Expansion Joint
6012-101	17200EJ 2" Threaded Braided Hose   304 SS
6012-102	Flange Blind 3"   150#   304 SS

6012-103	Flange Threaded 3"   150#   304 SS
6012-104	Flange Kit Blind 3"   150#   304 SS
6012-105	Flange Kit Threaded 3"   150#   304 SS

NO-LEAD: The weighted average of the wetted surface of this no-lead product contacted by consumable water contains less than one quarter of one percent (0.25%) lead.



A.Y. McDonald Mfg. Co.  
4800 Chavenelle Rd  
Dubuque, IA 52002

Toll Free: 1-800-292-2737  
sales@aymcdonald.com  
aymcdonald.com

A.Y. McDonald considers the information on this assembly drawing correct when published. Item and option availability, including specifications, are subject to change without notice.

Submitted by:

# SUBMITTAL DATA SHEET

Pump Repair Parts

## DuraMAC™ Booster Repair Parts (MICRO)

Repair Parts - Vertical Multistage Variable Speed Booster Systems

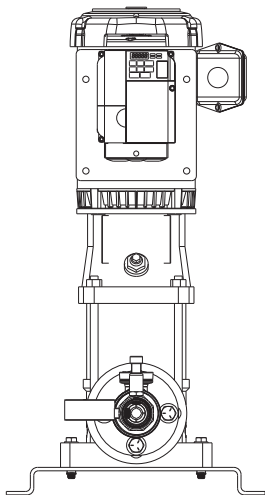

Simplex

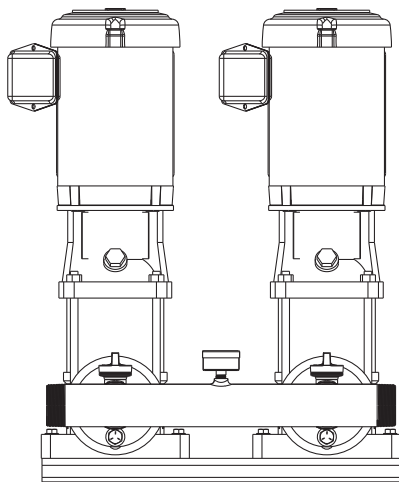

Duplex

### 1 1/2 HP - 3 HP Simplex / Duplex

Part No.	Description
6012-106	Transducer   4-20mA   150 PSI
6012-107	Transducer   4-20mA   200 PSI
6012-114	Seal Repair Part SiC / Carbon / EPDM
6012-115	Seal Repair Part SiC / SiC / EPDM - Sandy Water
6012-654	Pressure Gauge   200 PSI   Liquid filled
6011-537	Pressure Gauge   100 PSI   Liquid filled
6012-831	Pressure Gauge CBM   100 PSI   Liquid filled

#### MICRO - Contact Factory to insure correct drive programming

6012-582	Yaskawa Drive V1000 1 1/2 HP   1 Phase   230V
6012-583	Yaskawa Drive V1000 2 HP   1 Phase   230V
6012-584	Yaskawa Drive V1000 3 HP   1 Phase   230V
6012-585	Yaskawa Drive V1000 2 HP   3 Phase   230V
6012-586	Yaskawa Drive V1000 3 HP   3 Phase   230V
6012-588	Yaskawa Drive V1000 1 1/2 HP   3 Phase   230V
6012-832	Yaskawa Digital Operator

6012-515	Pump End 17103V020
6012-516	Pump End 17140V020
6012-518	Pump End 17066V040
6012-519	Pump End 17122V040
6012-587	Pump End 17110V040

6012-631	Motor TEFC - 1 1/2 HP Energy Eff 56C
6012-632	Motor TEFC - 2 HP Energy Eff 56C
6012-633	Motor TEFC - 3 HP Energy Eff 56C

### Dewatering Pump Repair parts:

#### Mini Mac Repair Kit

Part No.	Model No.	Description	Wt.	Price
6195-012	*300622RK	Impeller Repair Kit	1	\$39.00

NO-LEAD: The weighted average of the wetted surface of this no-lead product contacted by consumable water contains less than one quarter of one percent (0.25%) lead.



**A.Y. McDonald Mfg. Co.**  
4800 Chavenelle Rd  
Dubuque, IA 52002

**Toll Free: 1-800-292-2737**  
sales@aymcdonald.com  
aymcdonald.com

A.Y. McDonald considers the information on this assembly drawing correct when published. Item and option availability, including specifications, are subject to change without notice.

Submitted by: