

SUBMITTAL DATA SHEET

No-Lead Frostproof Sillcock
with Integral Vacuum Breaker - Anti-Siphon – 72011

MNPT or SWT x MGHT

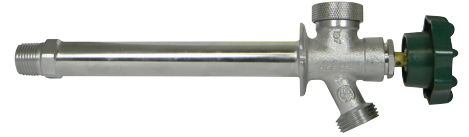

A.Y. McDonald Mfg. Co. No-Lead Frostproof Sillcocks provide a year round source of water to areas of structures that are subject to freezing temperatures. The hydrant valve is connected to supply piping in the heated portion of the structure, eliminating the possibility of freezing.

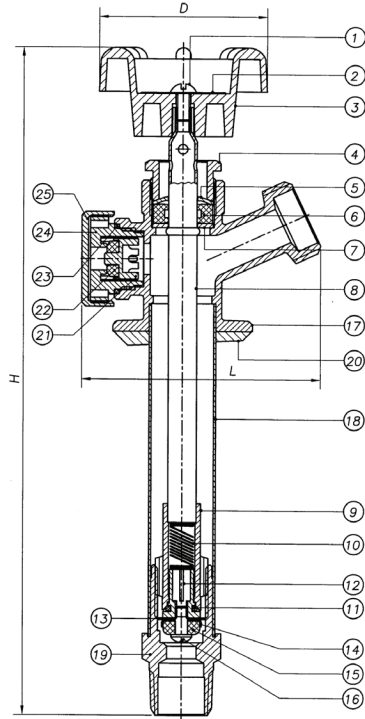

Dimensions

Part No.	Model No.	Size	D	H	L
5427-002	72011	1/2" x 3/4" x 2"	2.20	6.63	3.07
5420-023	72011	1/2" x 3/4" x 4"	2.20	8.64	3.07
5420-024	72011	1/2" x 3/4" x 6"	2.20	10.65	3.07
5420-025	72011	1/2" x 3/4" x 8"	2.20	12.66	3.07
5420-026	72011	1/2" x 3/4" x 10"	2.20	14.67	3.07
5420-027	72011	1/2" x 3/4" x 12"	2.20	16.71	3.07
5420-028	72011	1/2" x 3/4" x 14"	2.20	18.72	3.07

Materials

No.	Part	Material
1	Handle Bolt	No-Lead Brass
2	Name Plate	Aluminium
3	Handwheel	Zinc
4	Bonnet	No-Lead Brass
5	Washer	Stainless-Steel
6	Packing	Rubber (NBR)
7	Washer	Stainless-Steel
8	Stem Pipe	No-Lead Brass (Copper Alloy)
9	Stem	No-Lead Brass
10	Spring	Stainless-Steel
11	O-ring	Rubber (NBR)
12	Spring Seat	No-Lead Brass
13	Flapper	Rubber (NBR)
14	Seat Holder	No-Lead Brass
15	Seat Packing	Rubber (NBR)
16	Seat Screw	No-Lead Brass
17	Body	No-Lead Brass
18	Pipe Flow	No-Lead Brass (Copper Alloy)
19	Nipple	No-Lead Brass
20	Flange Packing	Formocon
21	Floating	Formocon
22	Floating Packing	Rubber (NBR)
23	O-ring	Rubber (NBR)
24	Bolt Packing	Formocon
25	Cap	No-Lead Brass

SUBMITTAL INFORMATION

- Inlet: 1/2" MNPT Thread or 1/2" Copper Sweat
- Outlet: 3/4" Garden Hose Thread
- Lengths: 2", 4", 6", 8", 10", 12", 14"
- Multi-Turn Operation
- 125 PSI
- Chrome Plated Body
- Complies with NSF/ANSI 372-2010
- ASSE 1019 - 2011

NO-LEAD: The weighted average of the wetted surface of this no-lead product contacted by consumable water contains less than one quarter of one percent (0.25%) lead.



A.Y. McDonald Mfg. Co.
4800 Chavenelle Rd
Dubuque, IA 52002

Toll Free: 1-800-292-2737
sales@aymcdonald.com
aymcdonald.com

A.Y. McDonald considers the information on this assembly drawing correct when published. Item and option availability, including specifications, are subject to change without notice.

Submitted by: