

# SUBMITTAL DATA SHEET

No-Lead  
Stub Out Elbow with Nail Flange – 2591

PEX x Spun Closed End

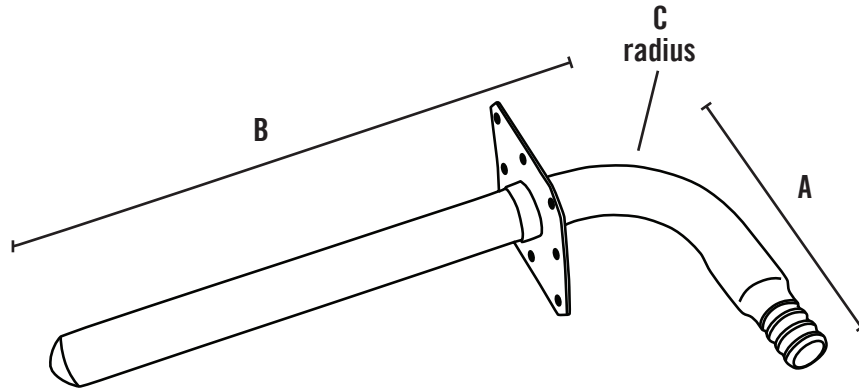

## Dimensions

PEX Connection	A	B	C
1/2"	3 1/2"	6"	1 1/4"
1/2"	3 1/2"	8"	1 1/4"
3/4"	4 1/2"	8"	1 1/4"

## SUBMITTAL INFORMATION

- Available Sizes: 1/2" x 3 1/2" x 6"  
1/2" x 3 1/2" x 8"  
3/4" x 4 1/2" x 8"
- 60 PSI
- Max Temperature: 392°F
- Material: C46500
- Pex end conforms to ASTM F1807
- Accepts sweet, push-fit and compression valves
- Nail to backing board for rigid installation

NO-LEAD: The weighted average of the wetted surface of this no-lead product contacted by consumable water contains less than one quarter of one percent (0.25%) lead.



**A.Y. McDonald Mfg. Co.**  
4800 Chavenelle Rd  
Dubuque, IA 52002

**Toll Free: 1-800-292-2737**  
sales@aymcdonald.com  
aymcdonald.com

A.Y. McDonald considers the information on this assembly drawing correct when published. Item and option availability, including specifications, are subject to change without notice.

**Submitted by:**