

SUBMITTAL DATA SHEET

Two Piece Brass Saddle - 3802

IPS PVC x FNPT



MODEL	SIZE	A	B	C	D	E	F
3802	2 X 1/2	1/2	1.21	2.20	1.47	HEX	2.375
3802	2 X 3/4	3/4	1.21	2.20	1.47	HEX	2.375
3802	2 X 1	1	1.21	2.20	1.69	HEX	2.375
3802	2 1/2 X 3/4	3/4	1.21	2.20	1.47	HEX	2.875
3802	2 1/2 X 1	1	1.21	2.20	1.69	HEX	2.875
3802	3 X 1/2	1/2	1.21	2.20	1.47	HEX	3.500
3802	3 X 3/4	3/4	1.21	2.20	1.47	HEX	3.500
3802	3 X 1	1	1.21	2.20	1.69	HEX	3.500
3802	4 X 1/2	1/2	1.21	2.56	1.47	HEX	4.500
3802	4 X 3/4	3/4	1.21	2.38	1.47	HEX	4.500
3802	4 X 1	1	1.21	2.56	1.69	HEX	4.500
3802	4 X 1 1/2	1 1/2	1.37	3.46	2.34	DCT	4.500
3802	4 X 2	2	1.37	3.72	2.82	DCT	4.500
3802	6 X 1/2	1/2	1.21	2.26	1.47	HEX	6.625
3802	6 X 3/4	3/4	1.21	2.26	1.47	HEX	6.625
3802	6 X 1	1	1.21	2.56	1.69	HEX	6.625
3802	6 X 1 1/2	1 1/2	1.37	3.46	2.34	DCT	6.625
3802	6 X 2	2	1.37	3.72	2.82	DCT	6.625
3802	8 X 1/2	1/2	1.33	2.56	1.69	HEX	8.625
3802	8 X 3/4	3/4	1.33	2.56	1.69	HEX	8.625
3802	8 X 1	1	1.33	2.56	1.69	HEX	8.625
3802	8 X 1 1/2	1 1/2	1.50	3.96	3.10	DCT	8.625
3802	8 X 2	2	1.50	3.96	3.10	DCT	8.625
3802	10 X 3/4	3/4	2.75	3.00	1.69	HEX	10.750
3802	10 X 1	1	2.75	3.00	1.69	HEX	10.750
3802	10 X 1 1/2	1 1/2	2.75	4.44	3.10	HEX	10.750
3802	10 X 2	2	2.75	4.44	3.10	HEX	10.750
3802	12 X 3/4	3/4	2.75	2.92	1.69	HEX	12.750
3802	12 X 1	1	2.75	2.92	1.69	HEX	12.750
3802	12 X 1 1/2	1 1/2	2.75	4.63	3.10	HEX	12.750
3802	12 X 2	2	2.75	4.63	3.10	HEX	12.750

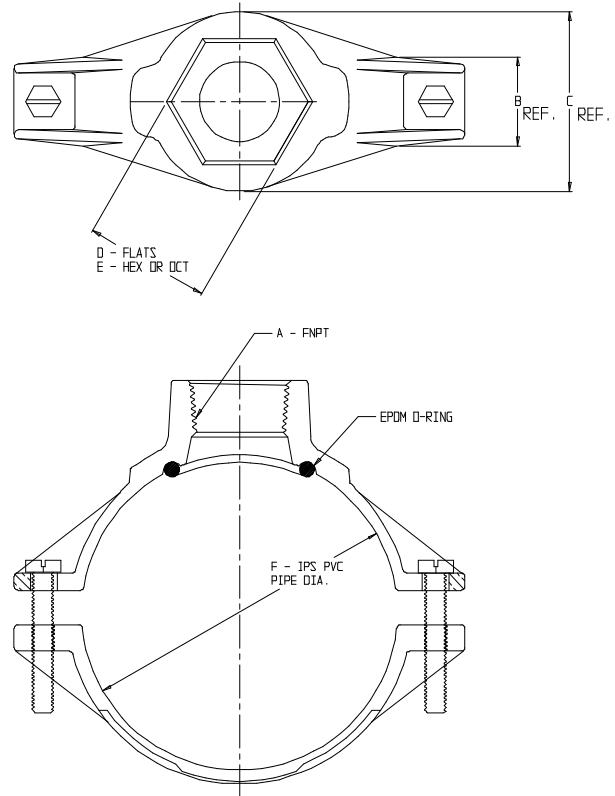

SUBMITTAL INFORMATION

- Manufactured in compliance with ANSI/AWWA C800 (latest revision)
- Brass components conform to ASTM B62 and ASTM B584, UNS C83600 -85-5-5-5 (latest revision)
- Certified to NSF/ANSI 61
- Silicon Bronze bolts
- EPDM o-ring
- Pipe and tap size, and thread type identified on saddle
- Outlet boss with large wrench flats



A.Y. McDonald Mfg. CO.
4800 Chavenelle Rd
Dubuque, IA 52002

Toll Free: 1-800-292-2737
sales@aymcdonald.com
aymcdonald.com

A.Y. McDonald considers the information on this assembly drawing correct when published. Item and option availability, including specifications, are subject to change without notice.

Submitted by: