

# SUBMITTAL DATA SHEET

## Iron Body Gas Ball Valves with Lockwing -855 Series

Meter Nut x FNPT

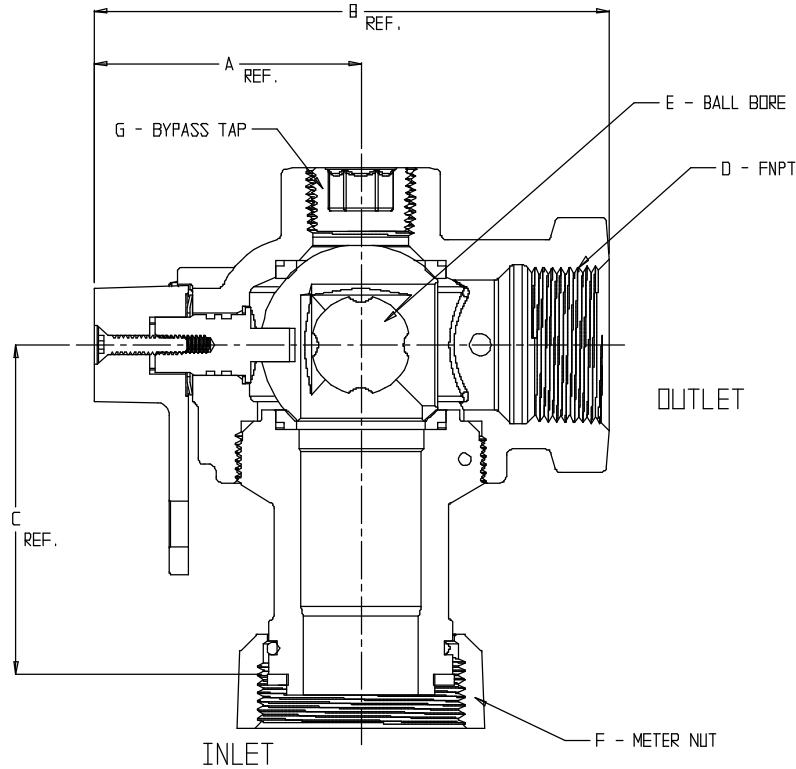

| SIZE          | A    | B    | C    | D     | E     | F                 | G                                   |
|---------------|------|------|------|-------|-------|-------------------|-------------------------------------|
| 1 X 3/4       | 2.05 | 4.32 | 2.69 | 1     | 3/4   | 20LT, 20LTO, 30LT | 3/4" RECESSED HEX, 3/4" SQUARE HEAD |
| 1 1/4 X 1 1/4 | 2.68 | 5.16 | 3.32 | 1 1/4 | 1 1/4 | 20LT, 20LTO, 30LT | 3/4" RECESSED HEX, 3/4" SQUARE HEAD |

### SUBMITTAL INFORMATION

- Manufactured in compliance with ANSI/ASME B16.33 (latest revision)
- Iron castings conform to ASTM A126 Class B Iron
- Optional Armorgalv® coating per ASTM A1059 (latest revision)
- UNS C36000 or CW617N brass ball rotates 90°
- Rated for 5 PSIG natural, manufactured, or LP gas pressure
- Blow out proof brass operating stem with two nitrile o-rings
- Tamper-resistant design prevents disassembly with normal household tools
- Lockwing design accommodates standard barrel locks
- Maintenance free design



**A.Y. McDonald Mfg. Co.**  
4800 Chavenelle Rd  
Dubuque, IA 52002

**Toll Free: 1-800-292-2737**  
sales@aymcdonald.com  
[aymcdonald.com](http://aymcdonald.com)

A.Y. McDonald considers the information on this assembly drawing correct when published. Item and option availability, including specifications, are subject to change without notice.

**Submitted by:**