

SUBMITTAL DATA SHEET

Gas Insulated Offset Swivels

MNPT

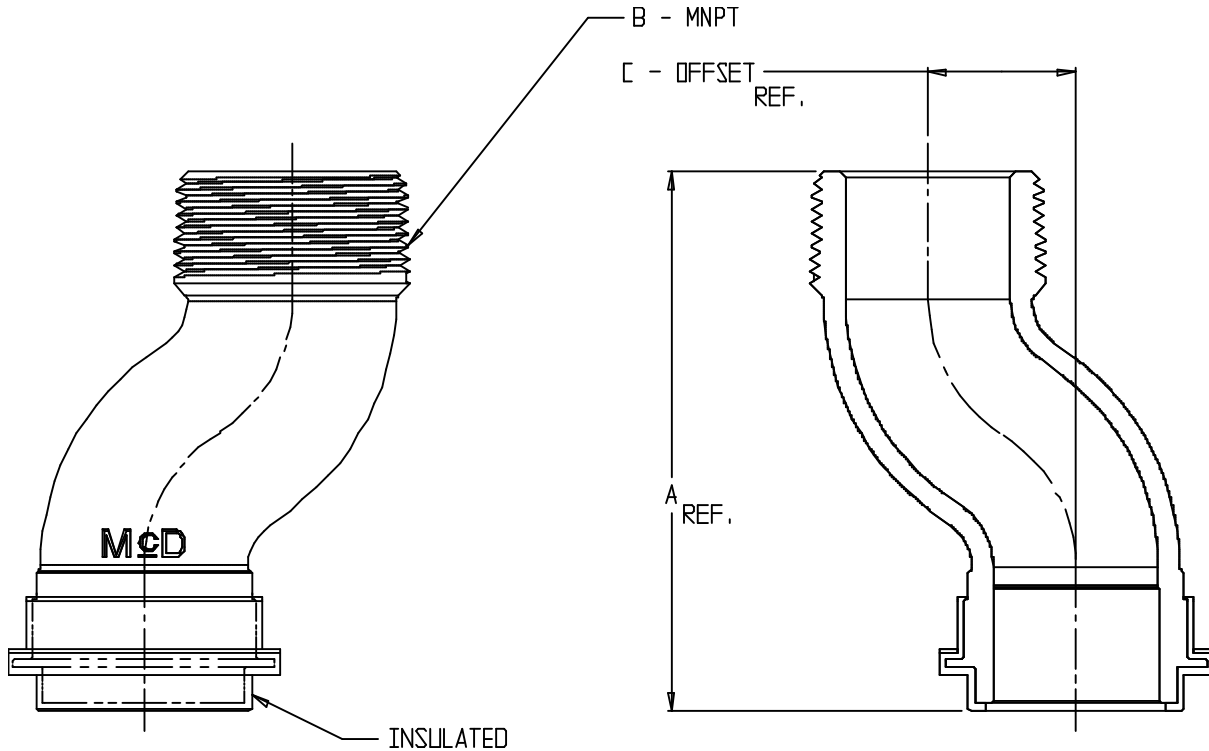

SIZE	ZINC PART NO.	A	B	C
1A	4815-765	2.75	3/4	1.03
20LT	4815-748	3.69	1	1.28

SUBMITTAL INFORMATION

- Manufactured in compliance with ANSI B109.1(latest revision)
- Iron castings conform to ASTM A47 or ASTM A536 (latest revision), with zinc coating applied after machining
- Pipe threads manufactured in compliance with ASME/ANSI B1.20.1 (latest revision)
- Molded Nylon insulation



A.Y. McDonald Mfg. Co.
4800 Chavenelle Rd
Dubuque, IA 52002

Toll Free: 1-800-292-2737
sales@aymcdonald.com
aymcdonald.com

A.Y. McDonald considers the information on this assembly drawing correct when published. Item and option availability, including specifications, are subject to change without notice.

Submitted by: