

SUBMITTAL DATA SHEET

NL Plug Style Corporation Stop – 73121

AWWA/CC x Increasing MNPT

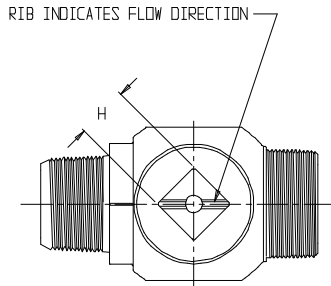

*NOTE: 1 1/2 & 2 INCH PLUGS HAVE SQUARE HEAD WRENCHING SURFACES

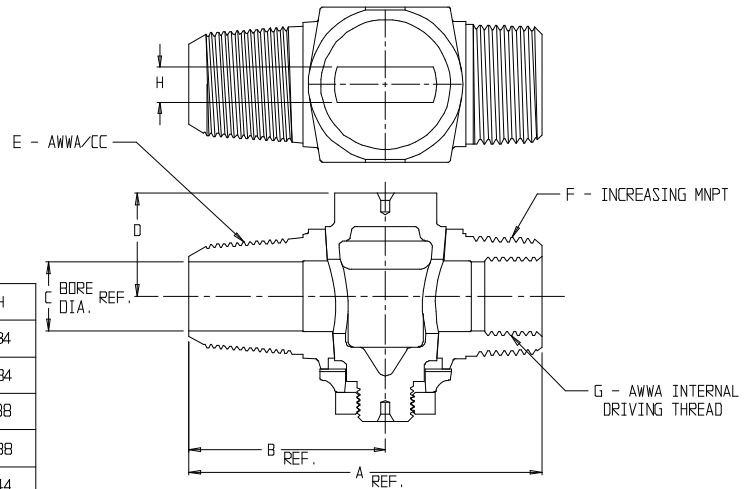

MODEL	SIZE	A	B	C	D	E	F	G	H
73121	1/2	3.13	1.74	.53	1.12	1/2	3/4	1/2	.34
73121	5/8	3.53	2.00	.63	1.10	5/8	3/4	5/8	.34
73121	3/4	3.86	2.15	.75	1.13	3/4	1	3/4	.38
73121	1	4.26	2.40	1.00	1.41	1	1 1/4	1	.38
73121	1 1/4	5.44	2.94	1.25	1.67	1 1/4	1 1/2	1 1/4	.44
73121	1 1/2	6.06	3.35	1.50	1.98	1 1/2	2	1 1/2	*1.13
73121	2	7.19	3.97	2.00	2.39	2	2 1/2	2	*1.25

SUBMITTAL INFORMATION

- Manufactured in compliance with ANSI/AWWA C800 (latest revision)
- Brass components in contact with potable water conform to ASTM B584, UNS C89833 (latest revision) and identified with “NL”
- Certified to NSF/ANSI 61 and NSF/ANSI 372
- Brass components not in contact with potable water conform to ASTM B62 and ASTM B584, UNS C83600 -85-5-5-5 (latest revision)
- Large wrench flats provided for proper installation
- Plug rotates 360°
- 1/2” – 1” rated for 100 PSIG water pressure
- 1 1/4” – 2” rated for 80 PSIG water pressure



A.Y. McDonald Mfg. Co.
4800 Chavenelle Rd
Dubuque, IA 52002

Toll Free: 1-800-292-2737
sales@aymcdonald.com
aymcdonald.com

A.Y. McDonald considers the information on this assembly drawing correct when published. Item and option availability, including specifications, are subject to change without notice.

Submitted by: