

SUBMITTAL DATA SHEET

Service Fitting – 4700Q

CTS Q-Comp Nut

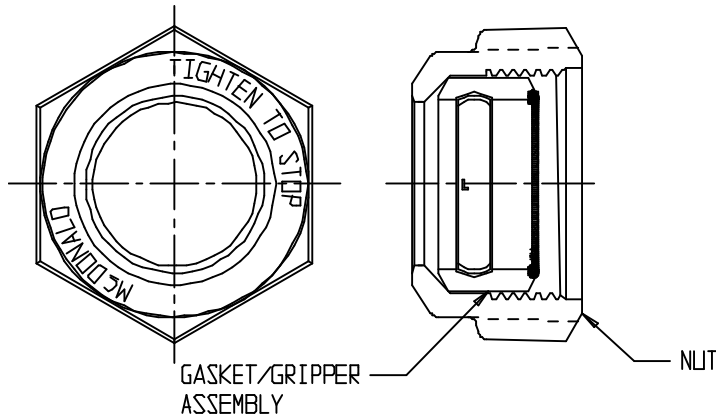

PLATE NO.	SIZE
4700Q 3/4	3/4 CTS
4700Q 1	1 CTS
4700Q 1 1/4	1 1/4 CTS
4700Q-12 1 1/2	1 1/2 CTS
4700Q-12 2	2 CTS
4700Q-16 1 1/2	* 1 1/2 CTS CO
4700Q-16 2	* 2 CTS CO

*NOTE: CORP ASSEMBLY NUTS MARKED "CO" BY A.Y. McDONALD.

SUBMITTAL INFORMATION

- Manufactured in compliance with ANSI/AWWA C800 (latest revision)
- Brass components conform to ASTM B62 and ASTM B584, UNS C83600 -85-5-5-5 (latest revision)
- Large wrench flats provided for proper installation
- Insert stiffeners required on all flexible plastic connections



A.Y. McDonald Mfg. Co.
4800 Chavenelle Rd
Dubuque, IA 52002

Toll Free: 1-800-292-2737
sales@aymcdonald.com
aymcdonald.com

A.Y. McDonald considers the information on this assembly drawing correct when published. Item and option availability, including specifications, are subject to change without notice.

Submitted by: