

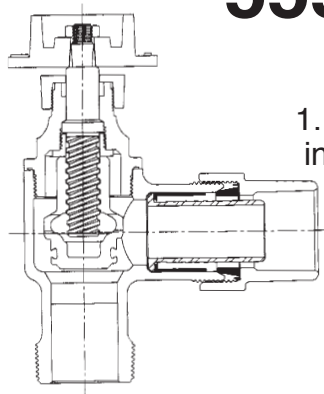

555 Angle Gas Valve



1. Read complete instructions before valve installation.
2. Inspect valves for foreign material. Remove any foreign material, being careful not to disturb the sealing surfaces of the valve.
3. Always apply a quality grade pipe thread sealant to the pipe thread before installation. Do **not** use teflon tape.

4. Always use wrenching flats nearest to connection point. Never insert a tool into the port area of the valve to thread it onto the pipe. Incorrect tightening or overtightening of the valve on installation can cause valve failure.

5. Installation torques should be reduced when using pipe heavier than schedule 40.

Caution: Never try to disassemble an A.Y. McDonald valve. If the valve is damaged or otherwise not functional, immediately remove the valve and replace it with a new one.

Installation of Compression End

- A. Cut off the plastic pipe squarely, making sure the exterior of the pipe has no marks or gouges, which may cause a leak past the sealing gasket.
- B. Slide the compression nut, gasket retainer and gasket over the end of the pipe.
- C. Insert the stiffener into the plastic pipe until the insert flange touches the end of the pipe.
- D. Reassemble nut onto body and tighten nut to a minimum 85 lbs. of pull on an 18" wrench. Make sure to tighten the nut using the wrenching lug on the body as well as the nut.