

Coiled Tube Pit Setter Installation Instructions

IMPORTANT NOTICE - READ CAREFULLY

Compression Connectors • General Information

1. Use a tube or pipe cutter to assure a square end. Make sure pipe is round. On copper tubing, use a rounding tool, if necessary. Surface should be clean.
2. Service tubing should always be **snaked** in the ditch.
3. **INSERT STIFFENERS MUST BE USED ON FLEXIBLE PLASTIC SERVICE TUBE OR PIPE.**
4. Stab tube or pipe through the nut and into the socket of the valve or fitting until it bottoms out (some fittings may or may not have a stop).
5. If the nut or socket appears too large or small, a check should be made to be sure you are using the correct fitting and pipe/tube.
6. **PRESSURE TEST FOR LEAKS BEFORE BACKFILLING.**
7. **USE ONLY ON COLD WATER SERVICES.**

Steel Pipe Size "55" Compression Connectors

Tighten the "55" Compression nut onto the valve or fitting to the following minimum torques.



This compresses the gasket for watertight

- 3/4" size 30 ft.-lbs.
- 1" size 35 ft.-lbs.
- 1 1/2" size 40 ft.-lbs.
- 2" size 45 ft.-lbs.

connections. Overtorquing nut by 10-20 ft.-lbs. will not affect connections.

Lock the pipe onto the nut by tightening the cup-point set screw(s) as follows (NOTE UNIT CHANGE):

- 3/4" size..... 3/4 - 1 turns (approx. 50 in.-lbs.)
- 1" size..... 1 1/2 - 2 turns (approx. 180 in.-lbs.)
- 1 1/2" size.. 1 1/2 - 1 3/4 turns (approx. 210 in.-lbs.)
- 2" size..... 1 1/2 - 1 3/4 turns (approx. 210 in.-lbs.)

Mac-Pak Compression Connectors (-22, -33, -44)

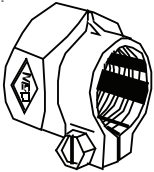

Tighten the Mac-Pak nut onto the valve or fitting to the following minimum torques. Overtorquing nut by 10-20 ft.-lbs. will not affect connections.

- 1/2" size 20 ft.-lbs.
- 3/4" size 25 ft.-lbs.
- 1" size 30 ft.-lbs.
- 1 1/4" size 35 ft.-lbs.
- 1 1/2" size 40 ft.-lbs.
- 2" size 45 ft.-lbs.

Lock the tube or pipe into the nut by securely tightening the split clamp side screw (use a box end or socket wrench, not a screwdriver). The torques to which the clamp side screw should be tightened are as follows (NOTE CHANGE IN UNITS).

- 1/2" size 70-80 in.-lbs.
- 3/4" size 80-90 in.-lbs.
- 1" size 90-100 in.-lbs.
- 1 1/4" size 120-140 in.-lbs.
- 1 1/2" size ... 160-180 in.-lbs.
- 2" size 200-220 in.-lbs.

A.Y. McDonald Mac-Pak Coding System

All A.Y. McDonald Mac-Pak fittings are coded to identify which type of service material they are designed to fit. Lettering is on the hex of the Mac-Pak nut.

***INSERT STIFFENERS MUST BE USED ON FLEXIBLE PLASTIC SERVICE TUBE OR PIPE.**

CTS

- Copper tube (Type K or L)
- PE tube per ASTM D2737 SDR 9 ONLY
- PB tube per ASTM D2666 SDR 9 Class 250 ONLY

PVC

- PVC pipe per ASTM D1785
- Steel pipe
- Brass pipe

*PEP

- PE pipe per ASTM D2239 SIDR 7 ONLY
- PB pipe per ASTM D2662 SIDR 7 Class 250 ONLY
- * was marked IPS until 2/02

T-Series (CTS) and -3T Series (PEP) Compression Connectors

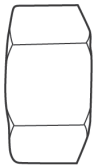

Tighten the compression nut onto the valve or fitting to the following minimum torques. Overtorquing nut by 5-10 ft.-lbs. will not affect connections.

T-Series

- 3/4" size 50 ft.-lbs.
- 1" size 55 ft.-lbs.
- 1 1/4" size 65 ft.-lbs.
- 1 1/2" size 100 ft.-lbs.
- 2" size 125 ft.-lbs.

-3T Series

- 3/4" size 55 ft.-lbs.
- 1" size 65 ft.-lbs.

() • Maximum pipe O.D. that will work with A.Y. McDonald fittings.

Types of Pipe/Tubing for use with

A.Y. McDonald Fittings (Outside Diameters listed)

NOMINAL SIZE	TYPE K or L COPPER TUBE	POLYETHYLENE ASTM D2737 SDR 9 TUBE SIZE*	POLYBUTYLENE ASTM D2666 SDR 9 TUBE SIZE CLASS 250 *	POLYETHYLENE ASTM D2239 SIDR 7 PIPE SIZE *	POLYBUTYLENE ASTM D2662 SIDR 7 CLASS 250*
3/4"	.872 .878	.871 .879	.875 .883	1.045 1.110 (1.089)	1.045 1.110 (1.089)
1"	1.121 1.129	1.120 1.130	1.125 1.135	1.329 1.399 (1.384)	1.329 1.399 (1.384)
1 1/4"	1.371 1.379	1.370 1.380	1.375 1.385	1.754 1.832 (1.804)	1.754 1.832 (1.804)
1 1/2"	1.621 1.630	1.619 1.631	1.625 1.637	2.050 2.141 (2.109)	2.050 2.141 (2.109)
2"	2.120 2.130	2.119 2.131	2.125 2.137	2.637 2.742 (2.709)	2.637 2.742 (2.709)

Ball Valves

1. Keep valve clean and free from dirt and debris.
2. Protect valve from freezing, which may distort ball. In the event the valve does freeze, do not forcibly try to open or close the valve while the valve is frozen. This may destroy the valve.
3. Use a snug fitting smooth jaw wrench on the wrenching flat nearest the tightened end. Do not wrench the body/endpiece joint.
4. Insert stiffeners **must** be used with all plastic tubing except PVC.
5. Always use an approved sealant or teflon tape on tapered pipe threads.
6. If valve has compression style connection, read connection instructions on reverse side prior to installation.
7. If the valve cap or stop box handle is perpendicular to the water line, the valve is closed. If the valve cap or stop box handle is inline with the water line, the valve is open. For standard valves with turning restraints (checks), turn the cap counter-clockwise to open and clockwise to close (unless ordered otherwise). Valves without turning restraints (checks) may be turned either direction to open or close.
8. Ball valves generally require low operating torques. If valve turns hard, check turning direction before applying excess force. Excess force can damage or destroy the turning restraints (checks) in the ball valve cap and body assembly.
9. All valves must be operated in the fully opened or fully closed position. Attempts to throttle flow by operating the valve in a partially open position may destroy the valve. If valve is used as a blowoff valve, contact the factory for proper procedure.
10. **PRESSURE TEST FOR LEAKS BEFORE BACKFILLING.**
11. **USE ONLY ON COLD WATER SERVICES.**

WARNING: Beginning January 1, 2010, it is unlawful in CALIFORNIA and VERMONT to use any product in the installation or repair of any public water system or any plumbing in a facility or system that provides water for human consumption if the wetted surface area of the product has a weighted average lead content greater than 0.25%. This prohibition does not extend to service saddles used in the state of CALIFORNIA.

Coiled Tube Pit Setter Installation Instructions

IMPORTANT NOTICE - READ CAREFULLY

Coiled Tube Pit Setters

- A. Prior to installation, verify setter dimensions are suitable for meter threads and laying length.
- B. Two gaskets are furnished for each meter for the new meter connections.
- C. DO NOT use Vaseline®, plumber's grease, or any other petroleum based product on seals or o-rings.
- D. For ease of installation, the top spacing for the new meter connection is designed to have clearance for the meter and two gaskets. Hand tighten BOTH meter nuts SIMULTANEOUSLY. Then, alternating between meter nuts, wrench tighten to assure a positive seal. Excess tightening may damage the gasket and cause leakage.
- E. Meter setters having compression ends are furnished with appropriate compression connection nuts and gaskets.
- F. PVC idler bars that come installed in setters are for shipping purposes ONLY. These PVC pipe nipples should NOT be used in a pressurized system.
- G. Do not remove idlers and plastic inlet and outlet MNPT protectors until installation to protect the valves and tubing from dirt and rodents.
- H. Do not let the tray free fall from the up position to prevent the tray and lower shelf from breaking. Do not over extend the tray out of the pit more than 2 ft. to avoid damaging the tubing and connections. The tray may not sit on the lower shelf evenly.
- I. Pit bottoms, insulation cushions, and lids are optional and are sold separately. If applicable, attach the bottom before placing the pit into the hole.
- J. Dig each trench to the proper depth for each pit setter.
- K. Place a layer of sand or crushed gravel in the bottom of the installation hole, or set the pit setter on blocks. Install the pit setter so that the top edge is at grade level.
- L. The inlet is marked on the outside of the pit with a I.D. label around the connection. The inlet valve is also marked on the inside of the pit.
- M. For 91 series pits: Both outlets are marked on the outside of the pit with an I.D. label around the connection. Both corresponding check valves/connections are also marked with a I.D. label on the inside of the pit.
- N. For 90 or 92 series pits: Outlet is marked on the outside of the pit with an I.D. label around the connection. The corresponding check valve/connection is also marked with a I.D. label on the inside of the pit.
- O. Wrench on the inlet and outlet MNPT connection flats when tightening the connections to prevent the coiled tube from kinking.
- P. Pressure test each coiled tube pit setter before backfilling the trench.
- Q. Backfill the hole evenly 12" at a time. Tamp each layer before filling in the next layer.
- R. Pit extensions are available. The minimum extension length is 2" and maximum length is 12".

Angle Single Check Backflow Preventers/Device

02 Series

Model Number Explanation

SPACE 1 & 2 Basic single check valve model number:
02=Angle valve

SPACE 3 (-) Standard
W = Pentagon test plug in cap

SPACE 4 Single check valve size: 3 = 3/4" 4 = 1"

SPACE 5 Inlet connection type:
H = Meter swivel integral with saddle
J = Meter swivel integral
Y = Yoke style thread male integral

SPACE 6 Outlet connection type:
E = Female iron pipe integral

COMPONENTS and REPAIR PARTS

SPACE 7 Thread size of meter swivel nut:

METER SIZE	THREAD SIZE	METER DESIGNATION
5/8	3/4"	3
5/8x3/4	1"	4
3/4	1"	4
1	1 1/4"	5

SPACE 8 Sizes for outlet connections:
3/4" = 3
1" = 4

Angle Dual Check Backflow Preventers/Device

Meets requirements of ASSE 1024 and CSA B64.6

12 Series

Model Number Explanation

SPACE 1 & 2 Basic dual check valve model number:
12=Angle valve

SPACE 3 (-) Standard
W= Pentagon test plug in cap

SPACE 4 Dual check valve size:
3 = 3/4" 4 = 1"

SPACE 5 Inlet connection type:
H - Meter swivel integral with saddle
J - Meter swivel integral
Y - Yoke style thread male integral

SPACE 6 Outlet connection type:
E=Female iron pipe integral
Q=CTS Q-Series compression integral
R=Copper flare integral
T=CTS T-Series compression integral
2=CTS (22) Mac-Pak compression integral

COMPONENTS and REPAIR PARTS

SPACE 7 Thread size of meter swivel nut:

METER SIZE	THREAD SIZE	METER DESIGNATION
5/8	3/4"	3
5/8x3/4	1"	4
3/4	1"	4
1	1 1/4"	5

SPACE 8 Sizes for outlet connections 3/4"=3 1"=4

Single & Dual Check Installation Instructions

- Use only for residential and mobile home supply service or individual outlets.
- The device can be installed in any position.
- The device shall be installed in an accessible location to facilitate the removal for servicing and testing.
- Service lines should be thoroughly flushed before installing the device. Excessive pipe sealant or Teflon tape may foul checks. A suitable strainer should be installed upstream of the device.
- Do NOT use Vaseline®, plumber's grease or any other petroleum based product on seals or o-rings.
- Insure that device is installed in proper flow direction. Refer to flow direction arrow.
- Do not over-tighten O-ring union nut seal or across body cylinder to avoid distortion.
- Any sweat fittings must be completed before installing device.
- A pressure relief valve or expansion tank is recommended downstream of device if thermal expansion conditions are possible.
- Use only on cold water services. Protect from freezing.
- Refer to pressure and temperature ratings on device tag.

CAUTIONS

A.Y. McDonald waterworks products are designed for reliable service. Like all brass products, however, they can be damaged by improper handling and use.

- Protect threads. Avoid loose fitting wrenches. Do not drop or impact.
- Use extra care with high water pressures (over 100 PSIG) and pipe or tubing over 1". Consult factory if desired.
- Inspect and test all joints, valves and fittings before backfilling.
- Backfill carefully so as to avoid damage to the service line and connections. Looping of the service lines is recommended to minimize strain.
- DO NOT use Vaseline®, plumber's grease, or any other petroleum based product on seals or o-rings.
- DO NOT pressurize system with factory installed PVC idler in place.

Damage caused by improper use and/or handling will void our warranty.

Field Inspection & Test Procedure

A. DIS-ASSEMBLY

- Remove the device cap.
- Remove the check assembly(ies) using care not to damage device components.
- Visually inspect seals, sealing surfaces, etc. for debris or damage.

B. TESTING

- Insert top check assembly into A.Y. McDonald angle test kit as shown in drawing.
- Add water to test kit level to upper red line - 42 inches (1.5 psig).
- Observe water level for up to 5 minutes. Water level should not fall below lower red line - 28 inches (1.0 psig).
- If water column falls below 28 inches the check assembly should be cleaned and re-tested or replaced.
- Repeat steps B1 - B4 for bottom check cartridge (for Dual Check only).

C. RE-ASSEMBLY

- Clean and inspect device components.
- Bottom Check cartridge O-ring should be lightly lubricated with a NSF approved silicone lubricant (for Dual Check only).
- Insert check assembly(ies) into body correctly corresponding to flow direction on the device body.
- Re-assemble device cap. Do not over-tighten.

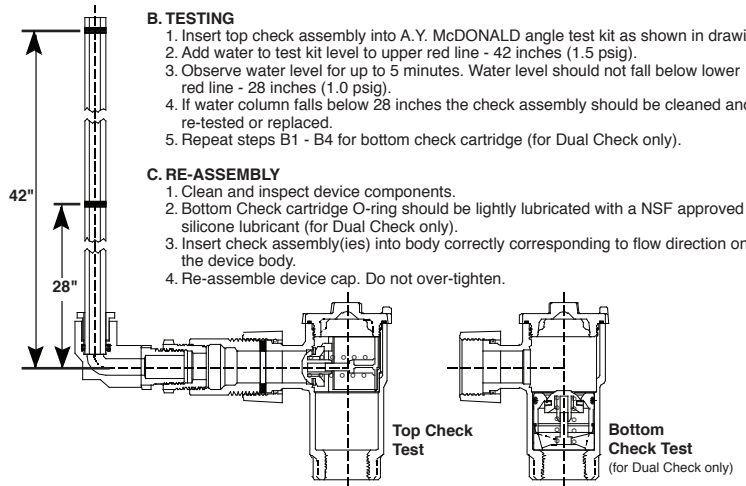

A.Y. McDonald Mfg. Co. 3/4" Angle Test Kit 4135-303