



# SUBMITTAL DATA

## 6762-C - UNION OUTLET INTEGRAL VALVE METER BAR FEATURES

A	B	C	WT
3/4	3/4*	20LT	6.0 lbs.
1	1	1A	5.8 lbs.
3/4	1	1A	5.6 lbs.
1	1	20LT	5.8 lbs.

\*3/4" outlet obtained with reducing endpiece.

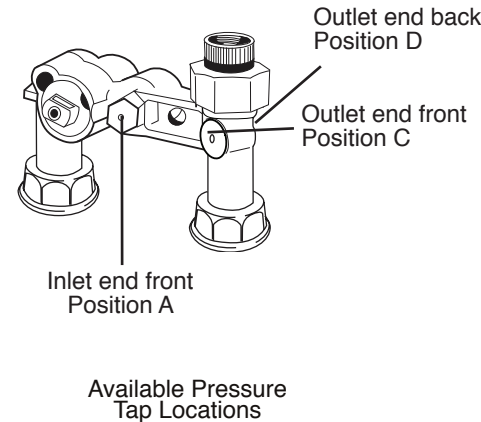
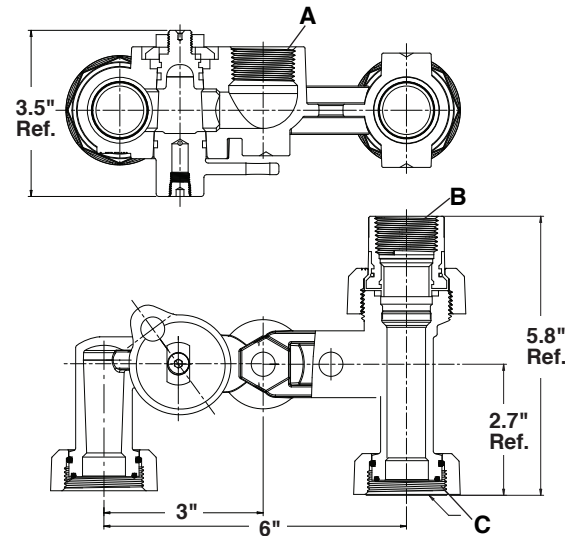

### PRESSURE TAP AND PLUG SIZES

- 1/8" NPT Recessed Hex Head Plug
- 1/8" NPT Square Head Plug
- 1/8" NPT - No Plug
- 1/4" NPT Recessed Hex Head Plug
- 1/4" NPT Square Head Plug
- 1/4" NPT - No Plug
- 3/8" NPT Recessed Hex Head Plug
- 3/8" NPT Square Head Plug
- 3/8" NPT - No Plug
- 1/8" NPT Square Head Plug - Raised Bosses (Position A & C only)
- 1/8" NPT Hex Head Plug - Raised Bosses (Position A & C only)
- 1/8" NPT Hex Head Plug

A.Y. McDonald Mfg. Co. Cast Iron Meter Bars have a heavy, one-piece I-Beam construction to protect the meter from piping stresses and ensure a solid installation.

### MATERIAL SPECIFICATIONS

METER BAR - Cast iron per ASTM A126 Class B

UNION NUT - Malleable iron per ASTM A47 or Ductile iron per ASTM A536

INSULATED UNION TAILPIECES - Zinc plated yellow dichromate finished steel with Zytel nylon insulation

FLAT GASKET/O-RINGS - Buna-N or neoprene suitable for use with natural, manufactured and L.P. gases

SWIVEL NUTS - Malleable iron per ASTM A47 or Ductile iron per ASTM A536

VALVE PLUG - Cast brass ASTM B 584/Alloy 83600 or Alloy 84400

VALVE NUT & WASHER - Cast brass ASTM B 584/Alloy 83600, Alloy 84400, or MPIF Std. 35 code CZ3002

### GAS METER BARS WITH CAST INTEGRAL SWIVELS

National Pipe Threads (NPT) are provided on the inlet and outlet tappings. Swivels are provided with flat gaskets or o-rings.

### INLET AND OUTLET CONNECTIONS

Female NPT inlet tapping provides a solid connection directly into the rear center of the bar, equipped with a 3/4" integral relubable valve. Outlets are provided with female NPT union type connections. Union connections have a flat gasket or o-ring seal.

### INSULATED UNION OUTLET

The union outlet is provided insulated to minimize electrolysis.

- Meter bars are electronically leak tested or equivalent at 90 PSIG.
- All connections with pipe threads require the use of a proven thread sealant at installation.

A.Y. McDONALD CONSIDERS THE INFORMATION ON THIS ASSEMBLY DRAWING CORRECT WHEN PUBLISHED. ITEM AND OPTION AVAILABILITY, INCLUDING SPECIFICATIONS, ARE SUBJECT TO CHANGE WITHOUT NOTICE. PLEASE VERIFY THAT PRODUCT INFORMATION IS CURRENT.

**A.Y. McDONALD MFG. CO. • P.O. BOX 508 • DUBUQUE, IA 52004-0508**

**800-292-2737 • FAX 800-832-9296 • sales@aymcdonald.com • www.aymcdonald.com**