



# SUBMITTAL DATA

## 4101B-22 CORPORATION STOPS - BALL VALVES

PART NO.	MODEL	SIZE	A	B	C	D	E	F	G
4131-317	4101B-22	3/4	4.39	2.14	2.42	.75	3/4	3/4	.30
4132-344	4101B-22	1	4.97	2.59	2.65	1.00	1	1	.30
4132-345	4101B-22	1 1/2	6.08	3.05	3.40	1.50	1 1/2	1 1/2	.40
4132-330	4101B-22	2	8.64	4.32	3.71	2.00	2	2	.40

- "Tee Head" Corp Stop design.
- Will not meet AWWA C-800 envelope requirements for fit to tapping machines.
- All cast brass conforms to AWWA Standard C800-01 (ASTM B-62, UNS C83600 – 85-5-5-5).
- Blowout proof cap and stem design.
- Cap and stem includes EPDM o-ring seals.
- Encapsulated lugs under cap provide 90° open to close operation.
- Brass Teflon coated (PTFE) ball for use in potable water systems.
- NSF 61 port seals - EPDM.
- 300 PSIG water working pressure.
- Compression type body includes internal pipe stop.
- Compression assemblies include Nitrile or EPDM rubber sealing gaskets and stainless steel set screw.
- Designed for use with potable water.

A.Y. McDONALD CONSIDERS THE INFORMATION ON THIS ASSEMBLY DRAWING CORRECT WHEN PUBLISHED. ITEM AND OPTION AVAILABILITY, INCLUDING SPECIFICATIONS, ARE SUBJECT TO CHANGE WITHOUT NOTICE. PLEASE VERIFY THAT PRODUCT INFORMATION IS CURRENT.

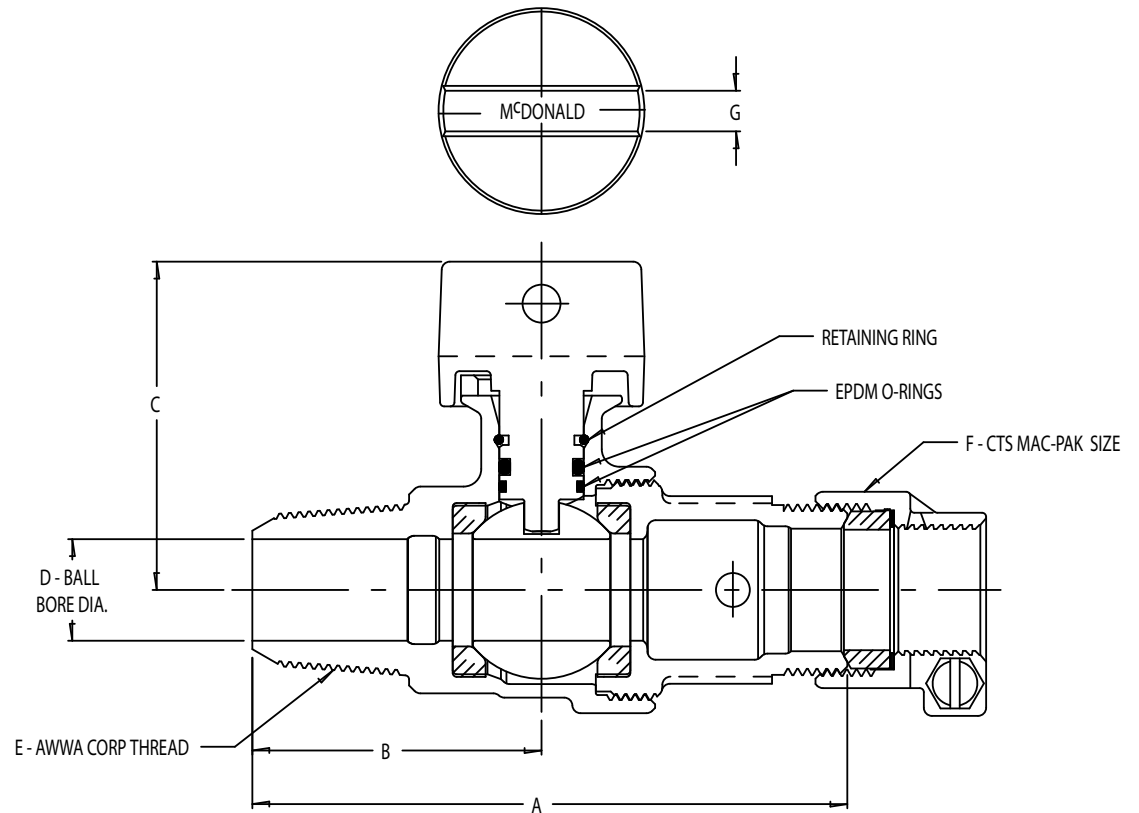

**A.Y. McDONALD MFG. CO. • P.O. BOX 508 • DUBUQUE, IA 52004-0508**  
**800-292-2737 • FAX 800-832-9296 • sales@aymcdonald.com • www.aymcdonald.com**

**PREPARED FOR:** \_\_\_\_\_  
**SUBMITTED BY:** \_\_\_\_\_  
**DATE:** \_\_\_\_\_