



SUBMITTAL DATA

4701BT CORPORATION STOPS - BALL VALVES

A. Y. McDONALD CONSIDERS THE INFORMATION ON THIS ASSEMBLY DRAWING CORRECT WHEN PUBLISHED. ITEM AND OPTION AVAILABILITY, INCLUDING SPECIFICATIONS, ARE SUBJECT TO CHANGE WITHOUT NOTICE. PLEASE VERIFY THAT PRODUCT INFORMATION IS CURRENT.

PART NO.	MODEL NO.	SIZE	A	B	C	D	E	F	G	H
4133-117	4701BT	3/4	4.22	1.96	.75	1.39	3/4"	3/4"	3/4"	.38
4139-159	4701BT	3/4 X 1	4.44	1.96	.75	1.39	3/4"	1"	1"	.38
4133-114	4701BT	1	4.37	2.11	1.00	1.50	1"	1"	1"	.28
4142-019	4701BT	1 X 1 1/4	4.51	2.11	1.00	1.50	1"	1 1/4"	1 1/4"	.28
4133-111	4701BT	1 1/2	6.08	3.05	1.50	2.15	1 1/2"	1 1/2"	1 1/2"	.42
4131-046	4701BT	1 1/2 X 2	6.96	3.05	1.50	2.15	1 1/2"	2"	2"	.42
4133-108	4701BT	2	7.53	3.21	2.00	2.46	2"	2"	2"	.42

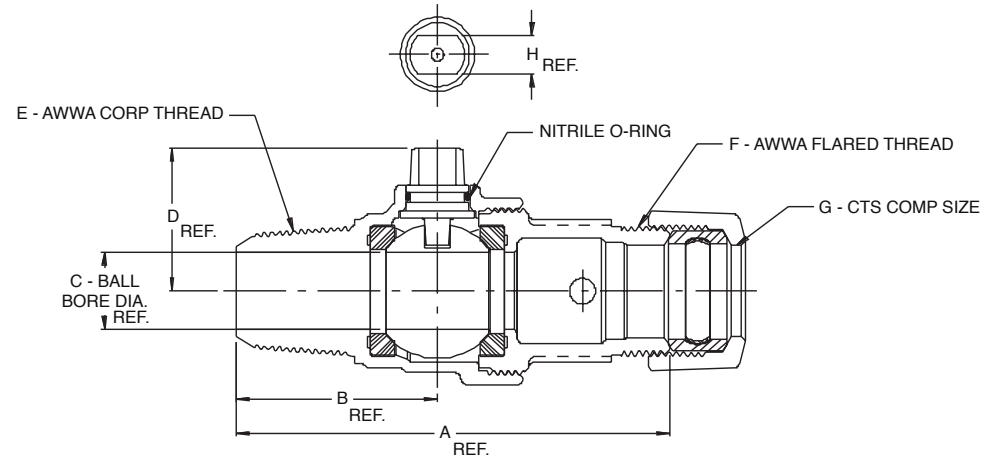

- All cast brass conforms to AWWA Standard C800-01 (ASTM B-62, UNS C83600 – 85-5-5-5).
- Throughway dimensions shall be no smaller than the nominal size of the valve.
- Valves are designed so they can be installed under pressure with standard tapping and drilling machine and instertion tools.
- Threads conform to current AWWA C800-01 standard.
- Body design includes heavy wrench flats for proper installation.
- Blowout proof cap and stem design.
- Brass Teflon coated (PTFE) ball for use in potable water systems.
- Buna-N or EPDM rubber seals held and sealed in place with adhesive.
- Rectangular operating head will be aligned such that the long side will indicate the direction of flow.

- Operating head is equipped with a BUNA-N or EPDM o-ring seal.
- 300 PSIG water working pressure.
- 360° rotation.
- Compression type bodies include internal pipe stop.
- Compression assemblies includes BUNA-N or EPDM rubber sealing gasket and stainless steel gripping ring.
- Designed for use with potable water.

A.Y. McDONALD MFG. CO. • P.O. BOX 508 • DUBUQUE, IA 52004-0508
 800-292-2737 • FAX 800-832-9296 • sales@aymcdonald.com • www.aymcdonald.com

PREPARED FOR: _____
 SUBMITTED BY: _____
 DATE: _____