

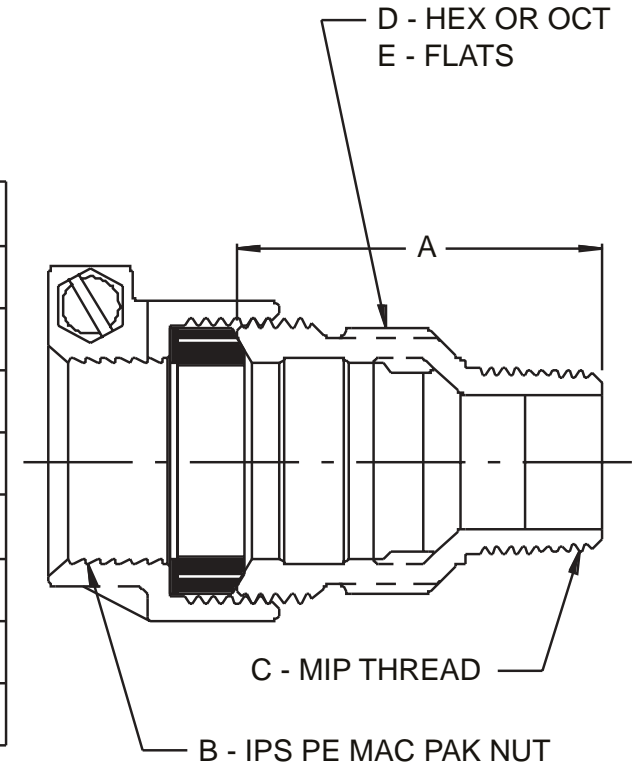

# SUBMITTAL DATA

## 4753-33 SERVICE FITTINGS & COUPLINGS

PART NO.	MODEL	SIZE	A	B	C	D	E
4142-122	4753-33	3/4	2.03	3/4	3/4	OCT	1.38
4130-065	4753-33	3/4 X 1	2.44	3/4	1	OCT	1.38
4142-123	4753-33	1	2.76	1	1	OCT	1.85
4132-229	4753-33	1 X 3/4	2.50	1	3/4	OCT	1.85
4131-009	4753-33	1 1/4	2.60	1 1/4	1 1/4	OCT	2.06
4131-012	4753-33	1 1/4 X 1 1/2	2.67	1 1/4	1 1/2	OCT	2.25
4131-017	4753-33	1 1/2	2.70	1 1/2	1 1/2	OCT	2.44
4131-028	4753-33	2	3.06	2	2	HEX	3.31



- All cast brass conforms to AWWA Standard C800-01 (ASTM B-62, UNS C83600 – 85-5-5-5).
- Body design provides large hexagonal or octagonal wrench flats for proper installation.
- Flare tube nut has large hex wrenching surfaces and long tube support body.
- Compression type bodies include internal pipe stop.
- Compression assemblies include one or more of the following: BUNA-N or EPDM rubber sealing gasket, imbedded electrical conduction spring, stainless steel gripping ring or stainless steel set screw.
- Designed for use with potable water.
- Materials meet or exceed A.W.W.A. standard C-800-01.

A.Y. McDONALD CONSIDERS THE INFORMATION ON THIS ASSEMBLY DRAWING CORRECT WHEN PUBLISHED. ITEM AND OPTION AVAILABILITY, INCLUDING SPECIFICATIONS, ARE SUBJECT TO CHANGE WITHOUT NOTICE. PLEASE VERIFY THAT PRODUCT INFORMATION IS CURRENT.

THIS PRINT IS THE PROPERTY OF A.Y. MCDONALD MFG. CO., DUBUQUE, IOWA AND IS LOANED SUBJECT TO RETURN UPON DEMAND. IT IS ISSUED WITH THE EXPRESSED AGREEMENT THAT IT WILL NOT BE ISSUED DIRECTLY OR INDIRECTLY IN ANY WAY DETRIMENTAL TO OUR INTERESTS. THE ACCEPTANCE OF THIS DRAWING WILL BE CONSTRUED AS AN ACCEPTANCE OF THE FOREGOING AGREEMENT.

**A.Y. McDONALD MFG. CO. • P.O. BOX 508 • DUBUQUE, IA 52004-0508**  
**800-292-2737 • FAX 800-832-9296 • sales@aymcdonald.com • www.aymcdonald.com**

**SUBMITTED BY:**