



# SUBMITTAL DATA

## 4754 SERIES FLARE x FIP COUPLING

A.Y. McDONALD CONSIDERS THE INFORMATION ON THIS ASSEMBLY DRAWING CORRECT WHEN PUBLISHED. ITEM AND OPTION AVAILABILITY, INCLUDING SPECIFICATIONS, ARE SUBJECT TO CHANGE WITHOUT NOTICE. PLEASE VERIFY THAT PRODUCT INFORMATION IS CURRENT.

PART NO.	MODEL	SIZE	A	B	C	D	E
4119-124	4754	1/2	1.56	1.06	HEX	1/2	1/2
4120-141	4754	3/4	1.72	1.31	HEX	3/4	3/4
4132-347	4754	3/4 X 1/2	1.82	1.38	HEX	3/4	1/2
4121-000	4754	3/4 X 1	1.95	1.52	OCT	3/4	1
4121-143	4754	1	2.15	1.63	HEX	1	1
4121-142	4754	1 X 3/4	1.86	1.40	HEX	1	3/4
4121-022	4754	1 X 1 1/4	2.19	2.00	HEX	1	1 1/4
4121-144	4754	1 1/4	2.44	2.38	HEX	1 1/4	1 1/4
4122-143	4754	1 1/2	2.56	2.56	HEX	1 1/2	1 1/2
4122-144	4754	2	3.06	3.04	HEX	2	2

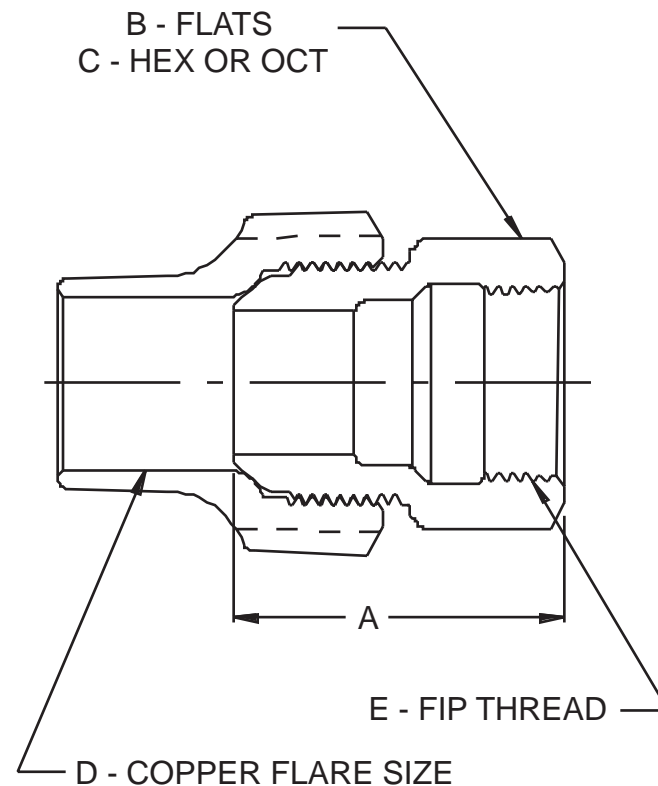

- All cast brass conforms to AWWA Standard C800-01 ASTM B-62, UNS C83600 – 85-5-5-5).
- Body design provides large hexagonal or octagonal wrench flats for proper installation.
- Flare tube nut has large hex wrenching surfaces and long tube support body.
- Designed for use with potable water.
- Threads conform to current A.W.W.A. C-800-01 standards.

**A.Y. McDONALD MFG. CO. • P.O. BOX 508 • DUBUQUE, IA 52004-0508**  
**800-292-2737 • FAX 800-832-9296 • sales@aymcdonald.com • www.aymcdonald.com**

**PREPARED FOR:** \_\_\_\_\_  
**SUBMITTED BY:** \_\_\_\_\_  
**DATE:** \_\_\_\_\_