

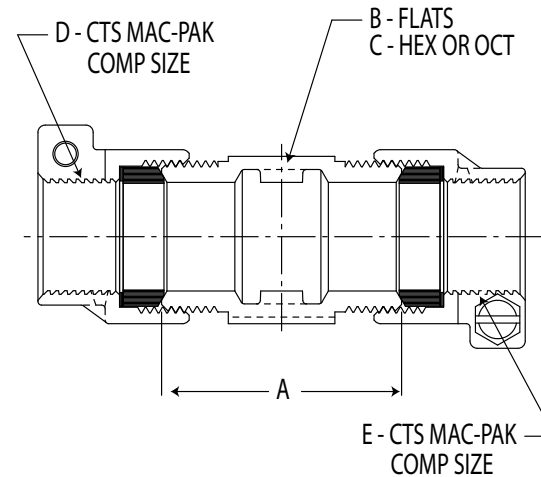

SUBMITTAL DATA

4758-22 SERIES STRAIGHT COUPLING - MAC-PAK COMPRESSION

PART NO.	MODEL	SIZE	A	B	C	D	E
4130-120	4758-22	1/2	1.60	1.06	HEX	1/2	1/2
4130-011	4758-22	1/2 X 3/4	1.80	1.38	HEX	1/2	3/4
4140-111	4758-22	3/4	2.00	1.34	OCT	3/4	3/4
4140-122	4758-22	3/4 X 1	2.11	1.38	OCT	3/4	1
4130-077	4758-22	3/4 X 1 1/4	2.10	1.69	HEX	3/4	1 1/4
4141-134	4758-22	1	2.40	1.38	OCT	1	1
4130-000	4758-22	1 X 1 1/4	2.61	1.85	OCT	1	1 1/4
4140-018	4758-22	1 X 1 1/2	2.60	1.85	OCT	1	1 1/2
4141-157	4758-22	1 1/4	2.64	1.69	HEX	1 1/4	1 1/4
4141-170	4758-22	1 1/2	3.31	2.00	OCT	1 1/2	1 1/2
4131-066	4758-22	1 1/2 X 2	2.62	2.44	OCT	1 1/2	2
4141-183	4758-22	2	3.53	2.45	OCT	2	2
4131-446	4758-22	2 1/2	3.25	3.12	OCT	2 1/2	2 1/2



- All cast brass conforms to current AWWA Standard C800 (ASTM B-62, UNS C83600 – 85-5-5-5).
- Body design provides large hexagonal or octagonal wrench flats for proper installation.
- Insert stiffeners are required on all flexible plastic connections.
- Compression type bodies include internal pipe stop.
- Mac-Pak Style Compression assembly includes EPDM rubber sealing gasket, anti-friction ring and stainless steel set screw.
- Fittings meet or exceed pressure requirements as set forth by AWWA C800 standards for underground service line valves and fittings.

- Designed for use with Type K or L Copper Tubing, tube size Polyethylene (ASTM D2737 SDR9) and tube size Polybutylene (ASTM D2666 SDR9 CLASS 250).
- Designed for use with above or below ground potable water applications with a temperature range of 34°F and 100°F.

A.Y. McDONALD CONSIDERS THE INFORMATION ON THIS ASSEMBLY DRAWING CORRECT WHEN PUBLISHED. ITEM AND OPTION AVAILABILITY, INCLUDING SPECIFICATIONS, ARE SUBJECT TO CHANGE WITHOUT NOTICE. PLEASE VERIFY THAT PRODUCT INFORMATION IS CURRENT.

PREPARED FOR: _____

SUBMITTED BY: _____

DATE: _____

(Specs-Straight Coup2.4130-120)

A.Y. McDONALD MFG. CO. • P.O. BOX 508 • DUBUQUE, IA 52004-0508
800-292-2737 • FAX 800-832-9296 • sales@aymcdonald.com • www.aymcdonald.com