

# SUBMITTAL DATA SHEET



## Ductile Iron Saddle with Stainless Steel Strap –4845AU

C900 PVC x AWWA/CC

MODEL	SIZE	A	B
4B45AU	4 X 3/4	3/4	4.50 - 4.80
4B45AU	4 X 1	1	4.50 - 4.80
4B45AU	4 X 1 1/4	1 1/4	4.50 - 4.80
4B45AU	4 X 1 1/2	1 1/2	4.50 - 4.80
4B45AU	4 X 2	2	4.50 - 4.80
4B45AU	6 X 3/4	3/4	6.63 - 6.90
4B45AU	6 X 1	1	6.63 - 6.90
4B45AU	6 X 1 1/4	1 1/4	6.63 - 6.90
4B45AU	6 X 1 1/2	1 1/2	6.63 - 6.90
4B45AU	6 X 2	2	6.63 - 6.90
4B45AU	8 X 3/4	3/4	8.63 - 9.05
4B45AU	8 X 1	1	8.63 - 9.05
4B45AU	8 X 1 1/4	1 1/4	8.63 - 9.05
4B45AU	8 X 1 1/2	1 1/2	8.63 - 9.05
4B45AU	8 X 2	2	8.63 - 9.05
4B45AU	10 X 3/4	3/4	10.75 - 11.10
4B45AU	10 X 1	1	10.75 - 11.10
4B45AU	10 X 1 1/4	1 1/4	10.75 - 11.10
4B45AU	10 X 1 1/2	1 1/2	10.75 - 11.10
4B45AU	10 X 2	2	10.75 - 11.10
4B45AU	12 X 3/4	3/4	12.75 - 13.20
4B45AU	12 X 1	1	12.75 - 13.20
4B45AU	12 X 1 1/4	1 1/4	12.75 - 13.20
4B45AU	12 X 1 1/2	1 1/2	12.75 - 13.20
4B45AU	12 X 2	2	12.75 - 13.20

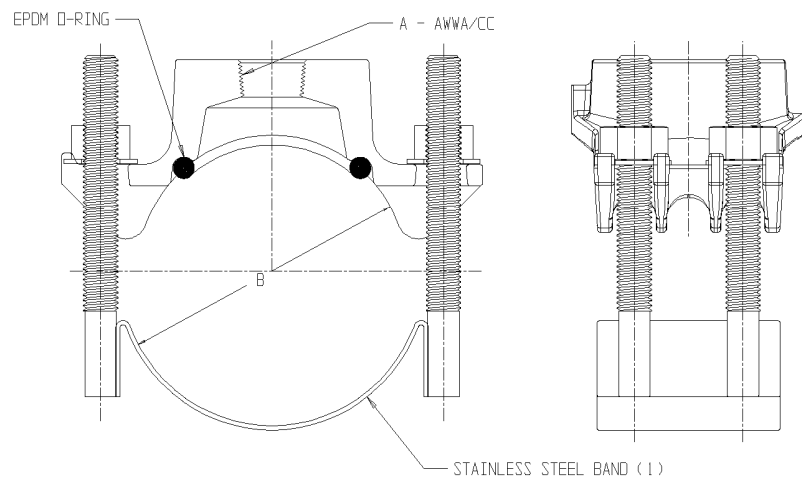
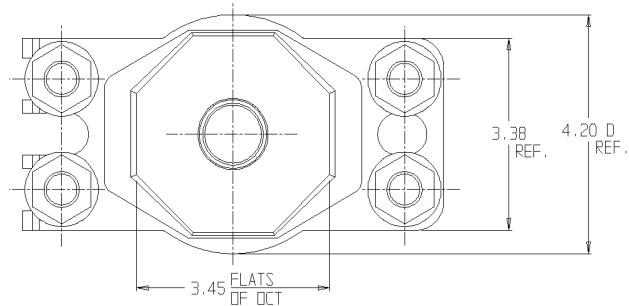

### SUBMITTAL INFORMATION

- Manufactured in compliance with ANSI/AWWA C800 (latest revision)
- Ductile iron conforms to ASTM A536 class 65-45-12 (latest revision)
- Certified to NSF/ANSI 61
- 304L Stainless Steel strap(s) and studs. Stainless steel nuts (PTFE coated) and washers
- EPDM o-ring
- Pipe and tap size, and thread type identified on saddle
- Outlet boss with large wrench flats
- Powder coated with blue epoxy
- Made in USA



**A.Y. McDonald Mfg. CO.**  
4800 Chavenelle Rd  
Dubuque, IA 52002

**Toll Free: 1-800-292-2737**  
sales@aymcdonald.com  
[aymcdonald.com](http://aymcdonald.com)

# SUBMITTAL DATA SHEET

Ductile Iron Saddle with Stainless Steel Strap -4845AU

C900 PVC x AWWA/CC



A.Y. McDonald considers the information on this assembly drawing correct when published. Item and option availability, including specifications, are subject to change without notice.