

SUBMITTAL DATA SHEET

Gas Meter Bars – 6600-C-- 1 X 1 X 1

FNPT x FNPT

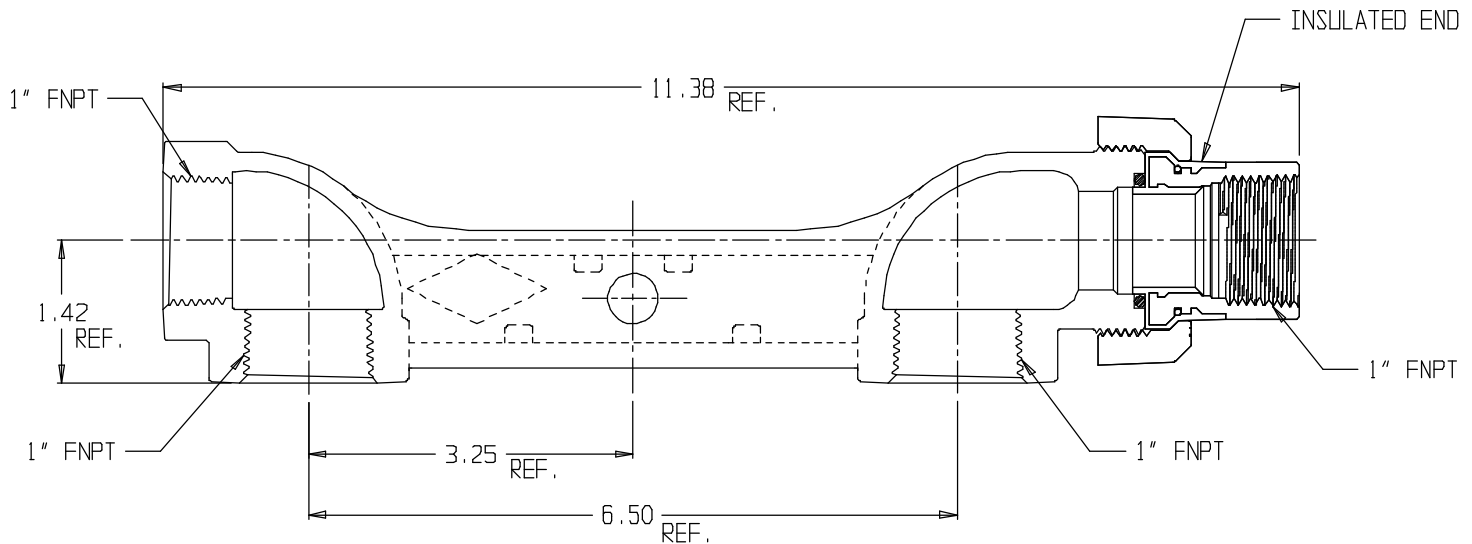

SUBMITTAL INFORMATION

- Iron castings conform to ASTM A126 Class B Iron
- Optional Armorgalv® coating per ASTM A1059 (latest revision)
- Pipe threads manufactured in compliance with ASME/ANSI B1.20.1 (latest revision)
- Pressure test taps available in multiple positions and sizes
- Rated for 2 PSIG natural, manufactured, or LP gas pressure



A.Y. McDonald Mfg. Co.
4800 Chavenelle Rd
Dubuque, IA 52002

Toll Free: 1-800-292-2737
sales@aymcdonald.com
aymcdonald.com

A.Y. McDonald considers the information on this assembly drawing correct when published. Item and option availability, including specifications, are subject to change without notice.

Submitted by:

02-22