

# SUBMITTAL DATA SHEET

Gas Meter Bars – 6610-B—1X1X1

FNPT x FNPT x FNPT

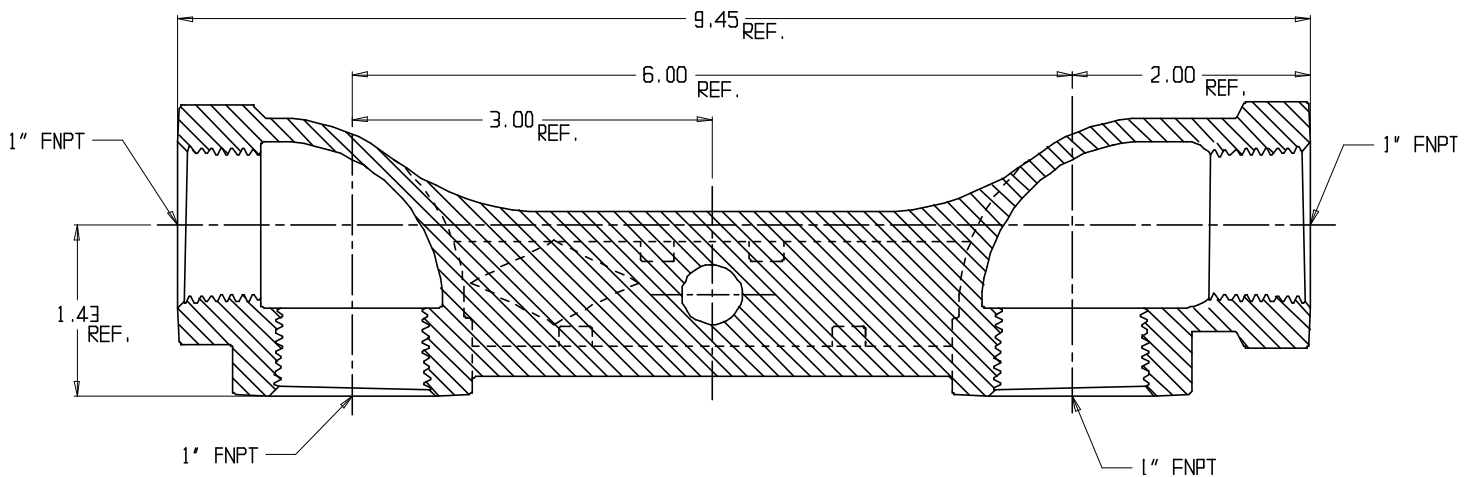

## SUBMITTAL INFORMATION

- Iron castings conform to ASTM A126 Class B Iron
- Optional Armorgalv ® coating per ASTM A1059 (latest revision)
- Pipe threads manufactured in compliance with ASME/ANSI B1.20.1 (latest revision)
- Pressure test taps available in multiple positions and sizes
- Rated for 2 PSIG natural, manufactured, or LP gas pressure



**A.Y. McDonald Mfg. Co.**  
4800 Chavenelle Rd  
Dubuque, IA 52002

**Toll Free: 1-800-292-2737**  
sales@aymcdonald.com  
[aymcdonald.com](http://aymcdonald.com)

A.Y. McDonald considers the information on this assembly drawing correct when published. Item and option availability, including specifications, are subject to change without notice.

**Submitted by:**