

SUBMITTAL DATA SHEET

Gas Meter Bars – 6762PRCEH- 1X1 1A

FNPT x FNPT

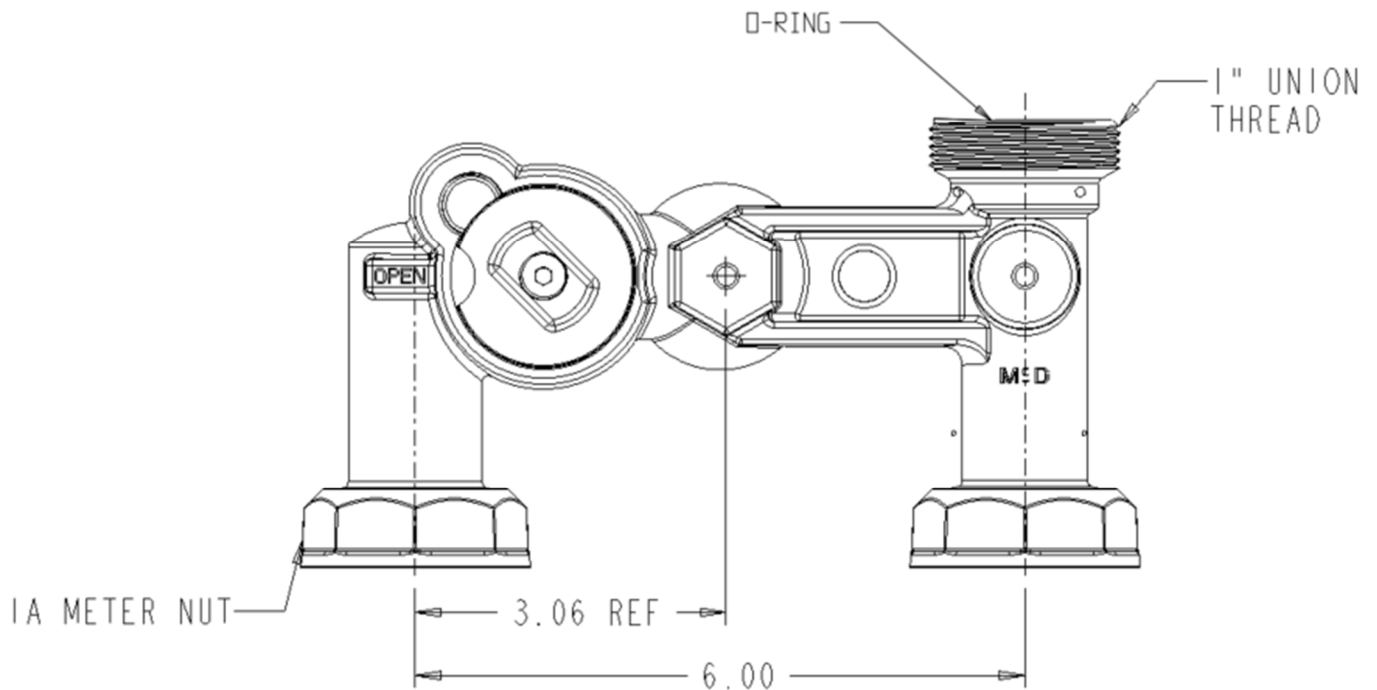

SUBMITTAL INFORMATION

- Iron castings conform to ASTM A126 Class B Iron (latest revision)
- Optional Armorgalv ® coating per ASTM A1059 (latest revision)
- Brass castings conform to ASTM B584, UNS C83600 or C84400 (latest revision)
- Pipe threads manufactured in compliance with ASME/ANSI B1.20.1 (latest revision)
- Rated for 2 PSIG natural, manufactured, or LP gas pressure
- Nuts castings conform to ASTM A49 or ASTM A536 (latest revision)
- Meter nuts and swivels manufactured in compliance with ANSI B109.1 (latest revision)
- Tamper-resistant design prevents disassembly with normal household tools
- Design accommodates standard barrel locks
- Pressure test taps available in multiple positions and sizes



A.Y. McDonald Mfg. Co.
4800 Chavenelle Rd
Dubuque, IA 52002

Toll Free: 1-800-292-2737
sales@aymcdonald.com
aymcdonald.com

A.Y. McDonald considers the information on this assembly drawing correct when published. Item and option availability, including specifications, are subject to change without notice.

Submitted by:

03-22