

SUBMITTAL DATA SHEET

NL Ball Style Corporation Stop – 73121B

AWWA/CC x Increasing MNPT

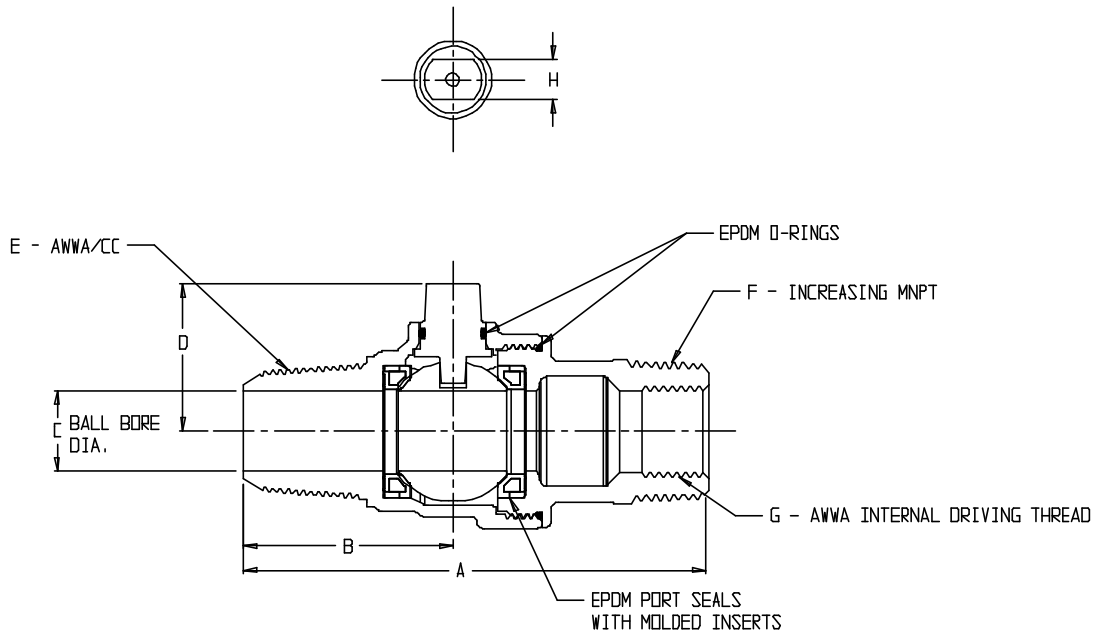

MODEL	SIZE	A	B	C	D	E	F	G	H
73121B	3/4	4.33	1.96	.75	1.39	3/4"	1"	3/4"	.38
73121B	1	4.46	2.11	1.00	1.50	1"	1 1/4"	1"	.28
73121B	1 1/4	6.53	3.02	1.25	1.88	1 1/4"	1 1/2"	1 1/4"	.42
73121B	1 1/2	6.56	3.05	1.50	2.15	1 1/2"	2"	1 1/2"	.42
73121B	2	6.96	3.21	2.00	2.46	2"	2 1/2"	2"	.42

SUBMITTAL INFORMATION

- Manufactured in compliance with ANSI/AWWA C800 (latest revision)
- Brass components in contact with potable water conform to ASTM B584, UNS C89833 (latest revision) and identified with "NL"
- Certified to NSF/ANSI 61 and NSF/ANSI 372
- Brass components not in contact with potable water conform to ASTM B62 and ASTM B584, UNS C83600 -85-5-5-5 (latest revision)
- PTFE coated brass ball rotates 360°
- Valve rated for 300 PSIG water pressure, end connections not to exceed rated pipe pressures.
- Blow out proof EPDM port seals
- End piece joint sealed with an EPDM o-ring and thread locker



A.Y. McDonald Mfg. Co.
4800 Chavenelle Rd
Dubuque, IA 52002

Toll Free: 1-800-292-2737
sales@aymcdonald.com
aymcdonald.com

A.Y. McDonald considers the information on this assembly drawing correct when published. Item and option availability, including specifications, are subject to change without notice.

Submitted by: