

SUBMITTAL DATA SHEET

NL Ball Style Corporation Stop – 74101BG

AWWA/CC x G CTS Compression

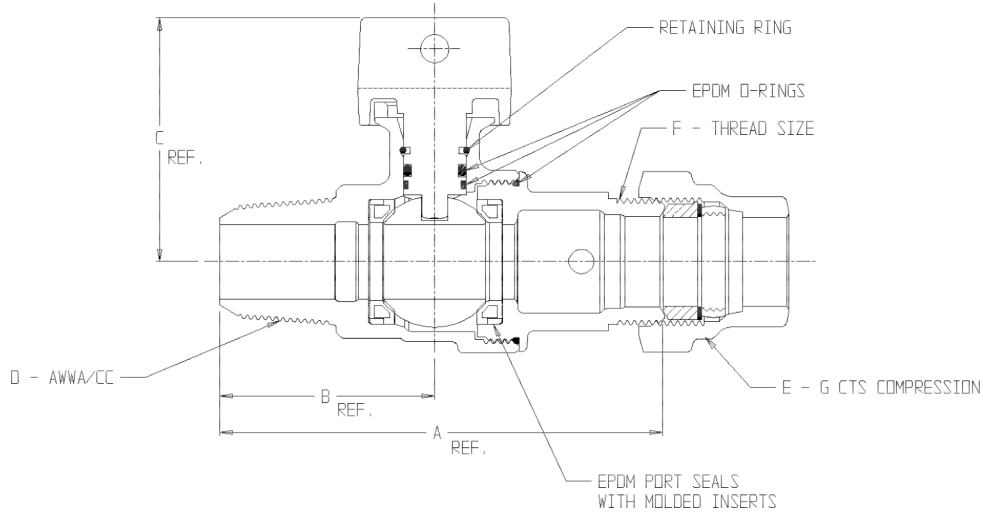

MODEL	SIZE	A	B	C	D	E	F
74101BG	3/4	4.40	2.14	2.42	3/4	3/4	3/4" AWWA FLARE
74101BG	1	5.07	2.59	2.65	1	1	1" AWWA FLARE
74101BG	1 1/2	6.42	3.05	3.40	1 1/2	1 1/2	2 1/8 -16 SPECIAL
74101BG	2	7.64	3.96	3.71	2	2	2 5/8 -16 SPECIAL

SUBMITTAL INFORMATION

- Manufactured in compliance with ANSI/AWWA C800 (latest revision)
- Brass components in contact with potable water conform to ASTM B584, UNS C89833 (latest revision) and identified with "NL"
- Certified to NSF/ANSI 61 and NSF/ANSI 372
- Brass components not in contact with potable water conform to ASTM B62 and ASTM B584, UNS C83600 -85-5-5-5 (latest revision)
- PTFE coated brass ball rotates 90°
- Valve rated for 300 PSIG water pressure, end connections not to exceed rated pipe pressure.
- Blow out proof EPDM port seals
- End piece joint sealed with an EPDM o-ring and thread locker
- Insert stiffeners required on all flexible plastic connections



A.Y. McDonald Mfg. Co.
4800 Chavenelle Rd
Dubuque, IA 52002

Toll Free: 1-800-292-2737
sales@aymcdonald.com
aymcdonald.com

A.Y. McDonald considers the information on this assembly drawing correct when published. Item and option availability, including specifications, are subject to change without notice.

Submitted by: