

SUBMITTAL DATA SHEET

NL Ball Style Corporation Stop – 74701B-55

AWWA/CC x -55 IP Compression

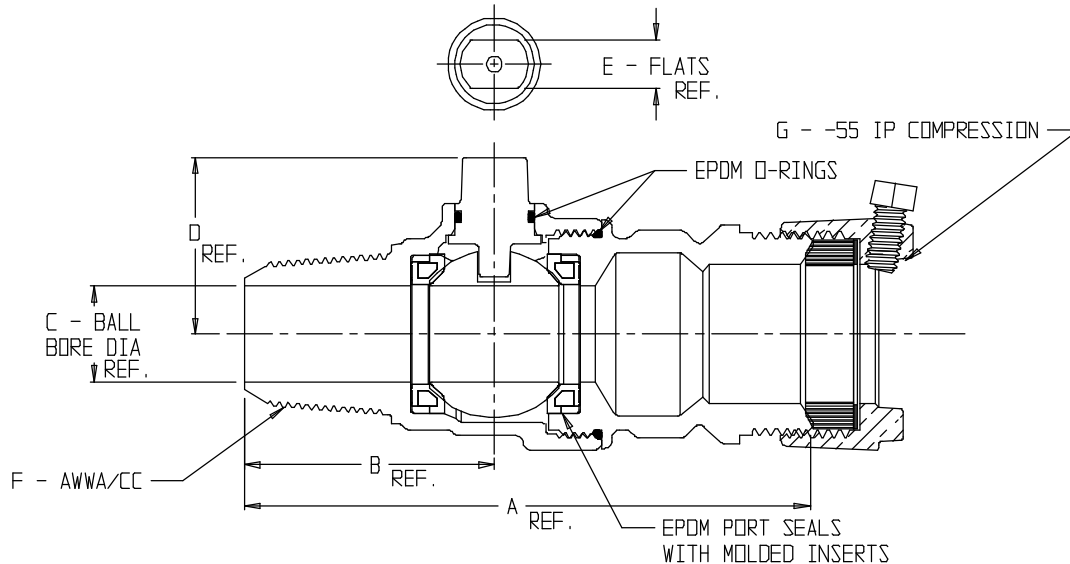

PLATE NO.	SIZE	A	B	C	D	E	F	G
74701B-55	3/4	4.44	1.96	.75	1.39	.38	3/4	3/4
74701B-55	3/4 X 1	4.49	1.96	.75	1.39	.38	3/4	1
74701B-55	1	4.63	2.15	1.00	1.50	.28	1	1
74701B-55	1 1/2	6.07	3.05	1.50	2.15	.42	1 1/2	1 1/2
74701B-55	2	7.66	3.21	2.00	2.46	.42	2	2

SUBMITTAL INFORMATION

- Manufactured in compliance with ANSI/AWWA C800 (latest revision)
- Brass components in contact with potable water conform to ASTM B584, UNS C89833 (latest revision) and identified with “NL”
- Certified to NSF/ANSI 61 and NSF/ANSI 372
- Brass components not in contact with potable water conform to ASTM B62 and ASTM B584, UNS C83600 -85-5-5-5 (latest revision)
- PTFE coated brass ball rotates 360°
- Valve rated for 300 PSIG water pressure, end connections not to exceed rated pipe pressures.
- Blow out proof EPDM port seals
- End piece joint sealed with an EPDM o-ring and thread locker



A.Y. McDonald Mfg. Co.
4800 Chavenelle Rd
Dubuque, IA 52002

Toll Free: 1-800-292-2737
sales@aymcdonald.com
aymcdonald.com

A.Y. McDonald considers the information on this assembly drawing correct when published. Item and option availability, including specifications, are subject to change without notice.

Submitted by: