

SUBMITTAL DATA SHEET

NL Ball Style Insulated Corporation Stop – 74704BDUQ

MNPT x Q CTS Compression

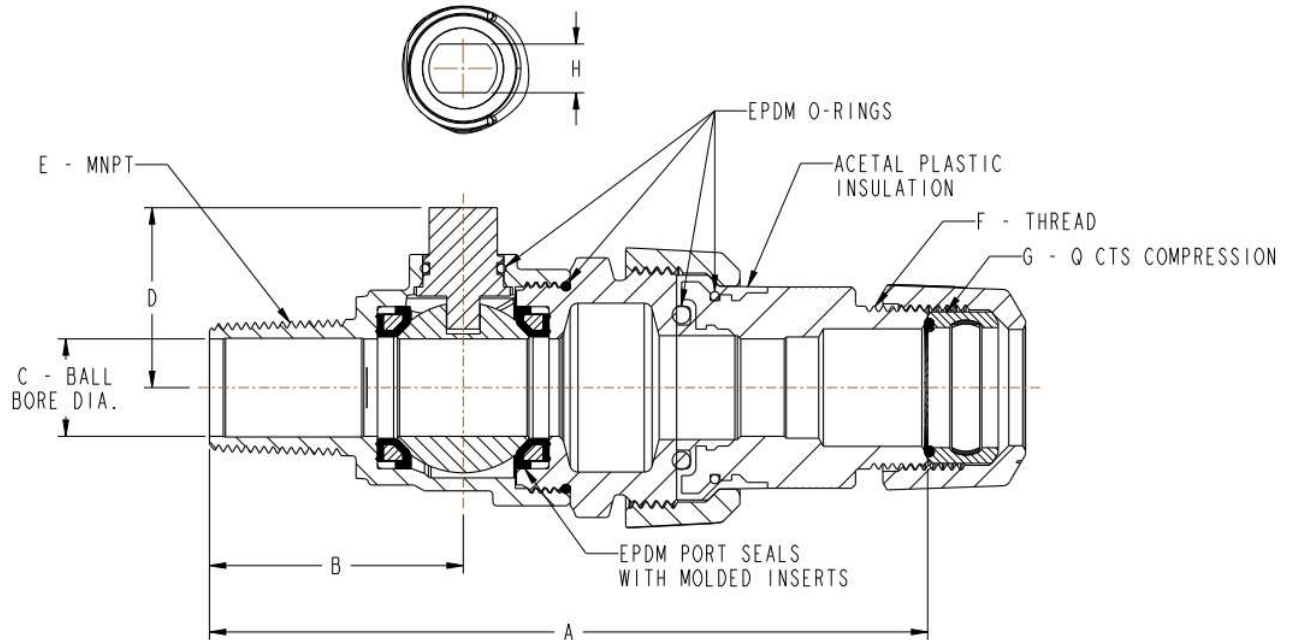
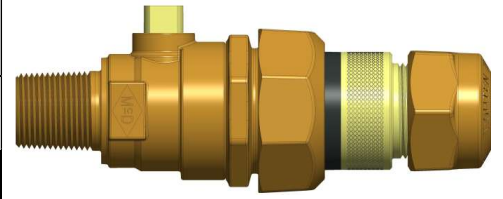

MODEL	SIZE	A	B	C	D	E	F	G	H
74704BDUQ	3/4	5.54	1.96	.75	1.39	3/4	3/4 AWWA FLARE	3/4	.38
74704BDUQ	1	6.27	2.15	1.00	1.50	1	1 AWWA FLARE	1	.28

SUBMITTAL INFORMATION

- Manufactured in compliance with ANSI/AWWA C800 (latest revision)
- Brass components in contact with potable water conform to ASTM B584, UNS C89833 (latest revision) and identified with “NL”
- Brass components not in contact with potable water conform to ASTM B62 and ASTM B584, UNS C83600 -85-5-5-5 (latest revision)
- PTFE coated brass ball rotates 360°
- Valve rated for 300 PSIG water pressure, end connections not to exceed rated pipe pressures.
- Blow out proof EPDM port seals
- End piece joint sealed with an EPDM o-ring and thread locker
- Insert stiffeners required on all flexible plastic connections
- All dimensions are for reference only



A.Y. McDonald Mfg. Co.
4800 Chavenelle Rd
Dubuque, IA 52002

Toll Free: 1-800-292-2737
sales@aymcdonald.com
aymcdonald.com

A.Y. McDonald considers the information on this assembly drawing correct when published. Item and option availability, including specifications, are subject to change without notice.

Submitted by: