

SUBMITTAL DATA SHEET

NL Stop and Waste Ball Curb Stop – 76000G

G CTS Compression x G CTS Compression

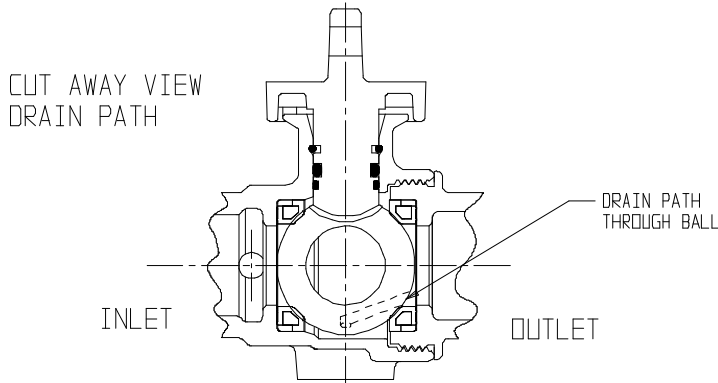

MODEL	SIZE	A	B	C	D	E
76000G	3/4	2.42	4.00	3/4	3/4	3/4
76000G	1	2.65	4.47	1	1	1
76000G	1 1/2	3.40	6.05	1 1/2	1 1/2	1 1/2
76000G	2	3.71	6.99	2	2	2

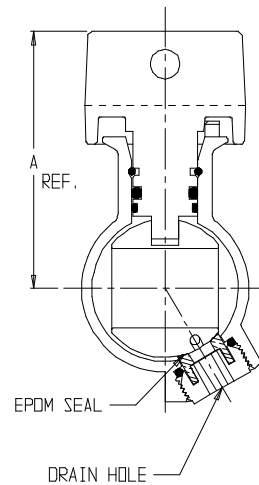
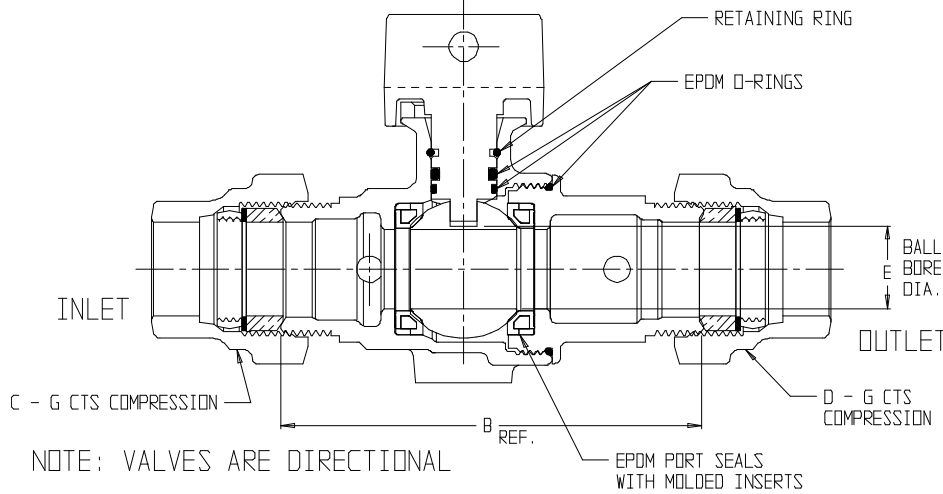

NOTE: VALVES ARE DIRECTIONAL

SUBMITTAL INFORMATION

- Manufactured in compliance with ANSI/AWWA C800 (latest revision)
- Brass components in contact with potable water conform to ASTM B584, UNS C89833 (latest revision) and identified with "NL"
- Certified to NSF/ANSI 61 and NSF/ANSI 372
- Brass components not in contact with potable water conform to ASTM B62 and ASTM B584, UNS C83600 -85-5-5-5 (latest revision)
- PTFE coated brass ball
- Rated for 150 PSIG water pressure with cast directional arrow
- Blow out proof EPDM port seals
- Joints sealed with EPDM o-rings and thread locker
- Insert stiffeners required on all flexible plastic connections



A.Y. McDonald Mfg. CO.
4800 Chavenelle Rd
Dubuque, IA 52002

Toll Free: 1-800-292-2737
sales@aymcdonald.com
aymcdonald.com

A.Y. McDonald considers the information on this assembly drawing correct when published. Item and option availability, including specifications, are subject to change without notice.

Submitted by: