

SUBMITTAL DATA SHEET

NL Ball Style Curb Stop – 76102W-55

-55 IP Compression x FNPT



DRAWING MAY NOT RESEMBLE ACTUAL VALVE CONFIGURATION

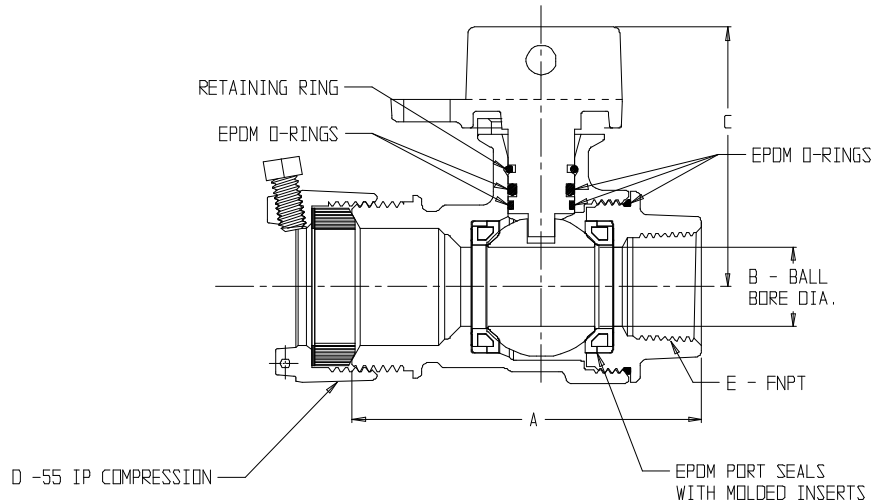

MODEL	SIZE	A	B	C	D	E
76102W-55	3/4 X 5/8 X 3/4	3.88	.63	2.31	3/4	3/4
76102W-55	3/4	3.27	.75	2.42	3/4	3/4
76102W-55	3/4 X 3/4 X 1	3.47	.75	2.42	3/4	1
76102W-55	3/4 X 1 X 1	3.76	1.00	2.64	3/4	1
76102W-55	1	4.18	1.00	2.64	1	1

SUBMITTAL INFORMATION

- Manufactured in compliance with ANSI/AWWA C800 (latest revision)
- Brass components in contact with potable water conform to ASTM B584, UNS C89833 (latest revision) and identified with “NL”
- Certified to NSF/ANSI 61 and NSF/ANSI 372
- Brass components not in contact with potable water conform to ASTM B62 and ASTM B584, UNS C83600 -85-5-5-5 (latest revision)
- PTFE coated brass ball
- Valve rated for 300 PSIG water pressure, end connections not to exceed rated pipe pressures.
- Blow out proof EPDM port seals
- End piece joint sealed with an EPDM o-ring and thread locker



A.Y. McDonald Mfg. Co.
4800 Chavenelle Rd
Dubuque, IA 52002

Toll Free: 1-800-292-2737
sales@aymcdonald.com
aymcdonald.com

A.Y. McDonald considers the information on this assembly drawing correct when published. Item and option availability, including specifications, are subject to change without notice.

Submitted by: