

SUBMITTAL DATA SHEET

Silicon Bronze Double Bale Saddle – 3825A/3825B

C903 PVC x AWWA/CC



MODEL	SIZE	A	B
3825A	14 X 3/4	3/4	15.30-16.25
3825B	14 X 3/4	3/4	16.30-17.25
3825A	14 X 1	1	15.30-16.25
3825B	14 X 1	1	16.30-17.25
3825A	14 X 1 1/2	1 1/2	15.30-16.25
3825B	14 X 1 1/2	1 1/2	16.30-17.25
3825A	14 X 2	2	15.30-16.25
3825B	14 X 2	2	16.30-17.25
3825A	16 X 3/4	3/4	17.40-18.40
3825B	16 X 3/4	3/4	18.50-19.25
3825A	16 X 1	1	17.40-18.40
3825B	16 X 1	1	18.50-19.25
3825A	16 X 1 1/2	1 1/2	17.40-18.40
3825B	16 X 1 1/2	1 1/2	18.50-19.25
3825A	18 X 2	2	17.40-18.40
3825B	18 X 2	2	18.50-19.25
3825A	20 X 3/4	3/4	21.20-22.20
3825B	20 X 3/4	3/4	22.50-23.50
3825A	20 X 1	1	21.20-22.20
3825B	20 X 1	1	22.50-23.50
3825A	20 X 1 1/2	1 1/2	21.20-22.20
3825B	20 X 1 1/2	1 1/2	22.50-23.50
3825A	20 X 2	2	21.20-22.20
3825B	20 X 2	2	22.50-23.50
3825A	24 X 3/4	3/4	23.80-24.80
3825B	24 X 3/4	3/4	25.60-26.50
3825A	24 X 1	1	23.80-24.80
3825B	24 X 1	1	25.60-26.50
3825A	24 X 1 1/2	1 1/2	23.80-24.80
3825B	24 X 1 1/2	1 1/2	25.60-26.50
3825A	24 X 2	2	23.80-24.80
3825B	24 X 2	2	25.60-26.50

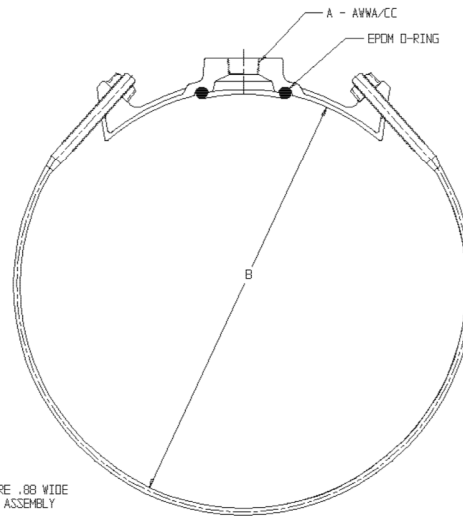
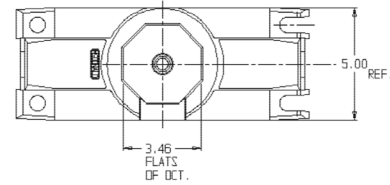

SUBMITTAL INFORMATION

- Manufactured in compliance with ANSI/AWWA C800 (latest revision)
- Brass components conform to ASTM B62 and ASTM B584, UNS C83600 -85-5-5-5 (latest revision)
- Certified to NSF/ANSI 61
- Silicon Bronze strap(s) and cast brass nuts with enlarged washer bearing surface
- EPDM o-ring
- Pipe and tap size, and thread type identified on saddle
- Outlet boss with large wrench flats



A.Y. McDonald Mfg. CO.
4800 Chavenelle Rd
Dubuque, IA 52002

Toll Free: 1-800-292-2737
sales@aymcdonald.com
aymcdonald.com

A.Y. McDonald considers the information on this assembly drawing correct when published. Item and option availability, including specifications, are subject to change without notice.

Submitted by: