

SUBMITTAL DATA SHEET

Silicon Bronze Strap Saddle - 3826

Ductile Iron/Cement-Asbestos/Cast Iron x FNPT



MODEL	SIZE	A	B	C	D	E	F
3826	4 X 3/4	3/4	3.19	3.19	1.69	HEX	4.74 - 5.40
3826	4 X 1	1	3.19	3.19	1.69	HEX	4.74 - 5.40
3826	4 X 1 1/2	1 1/2	3.19	4.19	3.10	DCT	4.74 - 5.40
3826	4 X 2	2	3.19	4.19	3.10	DCT	4.74 - 5.40
3826	6 X 3/4	3/4	3.19	3.19	1.69	HEX	6.84 - 7.50
3826	6 X 1	1	3.19	3.19	1.69	HEX	6.84 - 7.50
3826	6 X 1 1/4	1 1/4	3.19	4.19	3.10	DCT	6.84 - 7.50
3826	6 X 1 1/2	1 1/2	3.19	4.19	3.10	DCT	6.84 - 7.50
3826	6 X 2	2	3.19	4.19	3.10	DCT	6.84 - 7.50
3826	8 X 3/4	3/4	3.19	3.19	1.69	HEX	8.99 - 9.67
3826	8 X 1	1	3.19	3.19	1.69	HEX	8.99 - 9.67
3826	8 X 1 1/4	1 1/4	3.19	4.19	3.10	DCT	8.99 - 9.67
3826	8 X 1 1/2	1 1/2	3.19	4.19	3.10	DCT	8.99 - 9.67
3826	8 X 2	2	3.19	4.19	3.10	DCT	8.99 - 9.67
3826	10 X 3/4	3/4	3.19	3.19	1.69	HEX	11.04 - 12.12
3826	10 X 1	1	3.19	3.19	1.69	HEX	11.04 - 12.12
3826	10 X 1 1/2	1 1/2	3.19	4.19	3.10	DCT	11.04 - 12.12
3826	10 X 2	2	3.19	4.19	3.10	DCT	11.04 - 12.12
3826	12 X 3/4	3/4	3.19	3.19	1.69	HEX	13.20 - 14.38
3826	12 X 1	1	3.19	3.19	1.69	HEX	13.20 - 14.38
3826	12 X 1 1/2	1 1/2	3.19	4.19	3.10	DCT	13.20 - 14.38
3826	12 X 2	2	3.19	4.19	3.10	DCT	13.20 - 14.38
3826	18 X 3/4	3/4	4.93	5.00	3.46	DCT	19.50 - 20.50
3826	18 X 1	1	4.93	5.00	3.46	DCT	19.50 - 20.50
3826	18 X 1 1/2	1 1/2	4.93	5.00	3.46	DCT	19.50 - 20.50
3826	18 X 2	2	4.93	5.00	3.46	DCT	19.50 - 20.50
3826	30 X 3/4	3/4	4.93	5.00	3.46	DCT	31.74 - 32.74
3826	30 X 1	1	4.93	5.00	3.46	DCT	31.74 - 32.74
3826	30 X 1 1/2	1 1/2	4.93	5.00	3.46	DCT	31.74 - 32.74
3826	30 X 2	2	4.93	5.00	3.46	DCT	31.74 - 32.74

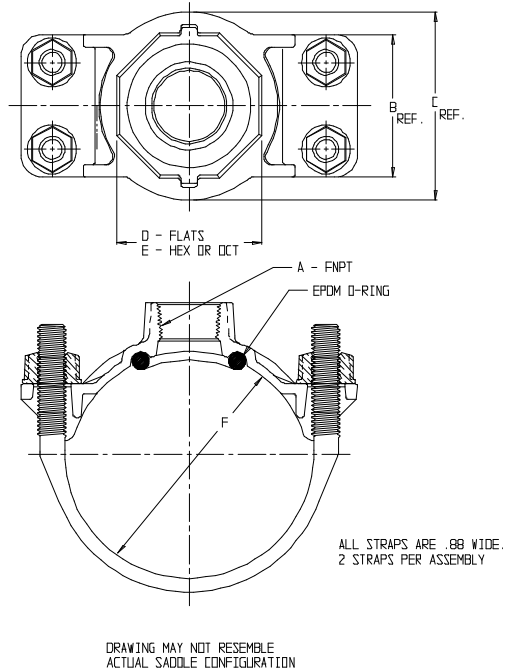

SUBMITTAL INFORMATION

- Manufactured in compliance with ANSI/AWWA C800 (latest revision)
- Brass components conform to ASTM B62 and ASTM B584, UNS C83600 -85-5-5-5 (latest revision)
- Certified to NSF/ANSI 61
- Silicon Bronze strap(s) and cast brass nuts with enlarged washer bearing surface
- EPDM o-ring
- Pipe and tap size, and thread type identified on saddle
- Outlet boss with large wrench flats



A.Y. McDonald Mfg. CO.
4800 Chavenelle Rd
Dubuque, IA 52002

Toll Free: 1-800-292-2737
sales@aymcdonald.com
aymcdonald.com

A.Y. McDonald considers the information on this assembly drawing correct when published. Item and option availability, including specifications, are subject to change without notice.

Submitted by: