

SUBMITTAL DATA SHEET

SS Strap Saddle - 3846

PVC x FNPT



MODEL	SIZE	A	B	C	D	E	F	G	PVC TYPE
3846	4 X 3/4	3/4	3.19	3.19	1.69	HEX	4.74 - 5.40	3.00	C900
3846	4 X 1	1	3.19	3.19	1.69	HEX	4.74 - 5.40	3.00	C900
3846	4 X 1 1/2	1 1/2	3.19	4.19	3.10	DCT	4.74 - 5.40	3.00	C900
3846	4 X 2	2	3.19	4.19	3.10	DCT	4.74 - 5.40	3.00	C900
3846	6 X 3/4	3/4	3.19	3.19	1.69	HEX	6.84 - 7.50	3.00	C900
3846	6 X 1	1	3.19	3.19	1.69	HEX	6.84 - 7.50	3.00	C900
3846	6 X 1 1/2	1 1/2	3.19	4.19	3.10	DCT	6.84 - 7.50	3.00	C900
3846	6 X 2	2	3.19	4.19	3.10	DCT	6.84 - 7.50	3.00	C900
3846	8 X 3/4	3/4	3.19	3.19	1.69	HEX	8.99 - 9.67	3.00	C900
3846	8 X 1	1	3.19	3.19	1.69	HEX	8.99 - 9.67	3.00	C900
3846	8 X 1 1/2	1 1/2	3.19	4.19	3.10	DCT	8.99 - 9.67	3.00	C900
3846	8 X 2	2	3.19	4.19	3.10	DCT	8.99 - 9.67	3.00	C900
3846	10 X 3/4	3/4	3.19	3.19	1.69	HEX	11.04 - 12.12	3.00	C900
3846	10 X 1	1	3.19	3.19	1.69	HEX	11.04 - 12.12	3.00	C900
3846	10 X 1 1/2	1 1/2	3.19	4.19	3.10	DCT	11.04 - 12.12	3.00	C900
3846	10 X 2	2	3.19	4.19	3.10	DCT	11.04 - 12.12	3.00	C900
3846	12 X 3/4	3/4	3.19	3.19	1.69	HEX	13.14 - 14.58	3.00	C900
3846	12 X 1	1	3.19	3.19	1.69	HEX	13.14 - 14.58	3.00	C900
3846	12 X 1 1/2	1 1/2	3.19	4.19	3.10	DCT	13.14 - 14.58	3.00	C900
3846	12 X 2	2	3.19	4.19	3.10	DCT	13.14 - 14.58	3.00	C900
3846	18 X 3/4	3/4	4.93	5.00	3.46	DCT	19.50 - 20.50	5.00	C905
3846	18 X 1	1	4.93	5.00	3.46	DCT	19.50 - 20.50	5.00	C905
3846	18 X 1 1/2	1 1/2	4.93	5.00	3.46	DCT	19.50 - 20.50	5.00	C905
3846	18 X 2	2	4.93	5.00	3.46	DCT	19.50 - 20.50	5.00	C905
3846	30 X 3/4	3/4	4.93	5.00	3.46	DCT	31.74 - 32.74	5.00	C905
3846	30 X 1	1	4.93	5.00	3.46	DCT	31.74 - 32.74	5.00	C905
3846	30 X 1 1/2	1 1/2	4.93	5.00	3.46	DCT	31.74 - 32.74	5.00	C905
3846	30 X 2	2	4.93	5.00	3.46	DCT	31.74 - 32.74	5.00	C905

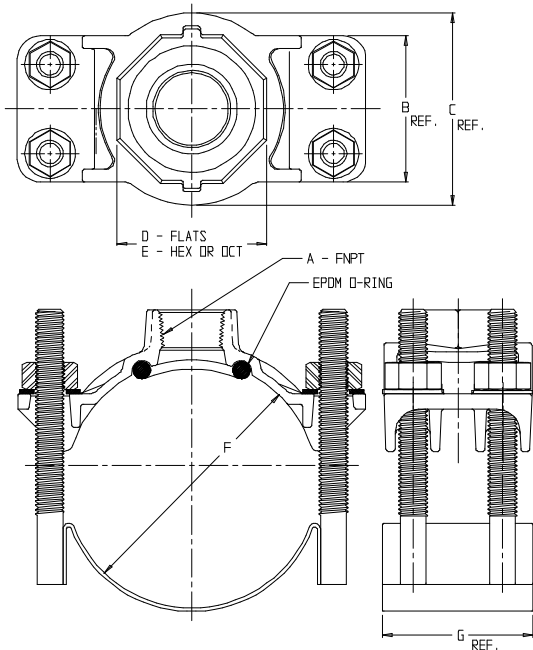

** ALL STAINLESS STEEL STRAP, ONE STRAP (WITH 4 STUDS WELDED ON) PER ASSEMBLY.

DRAWING MAY NOT RESEMBLE ACTUAL SADDLE CONFIGURATION

SUBMITTAL INFORMATION

- Manufactured in compliance with ANSI/AWWA C800 (latest revision)
- Brass components conform to ASTM B62 and ASTM B584, UNS C83600 -85-5-5-5 (latest revision)
- Certified to NSF/ANSI 61
- 304L Stainless Steel strap(s) and studs. Stainless steel nuts (PTFE coated) and washers
- EPDM o-ring
- Pipe and tap size, and thread type identified on saddle
- Outlet boss with large wrench flats



A.Y. McDonald Mfg. CO.
4800 Chavenelle Rd
Dubuque, IA 52002

Toll Free: 1-800-292-2737
sales@aymcdonald.com
aymcdonald.com

A.Y. McDonald considers the information on this assembly drawing correct when published. Item and option availability, including specifications, are subject to change without notice.

Submitted by: