

SUBMITTAL DATA SHEET

Sump, Sewage, & Effluent Pumps
DuraMAC™ | Guardian

5050CUEF, 5050CTEF, & 5050CTEF25 Effluent Pump



See Pumps & Accessories
Price List for Limited
Warranty details.

With a rugged cast iron construction, the 5050C Series can handle up to 70 gallons per minute (GPM).

Performance Curve

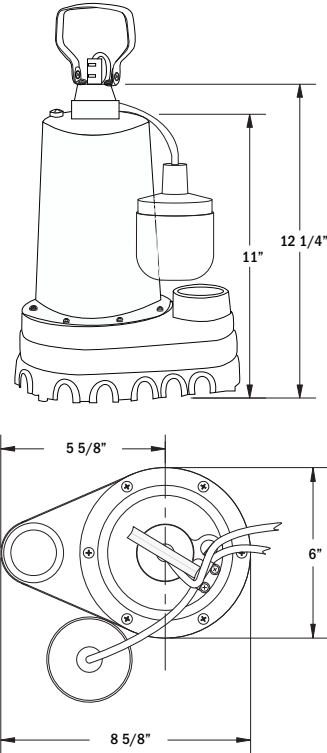
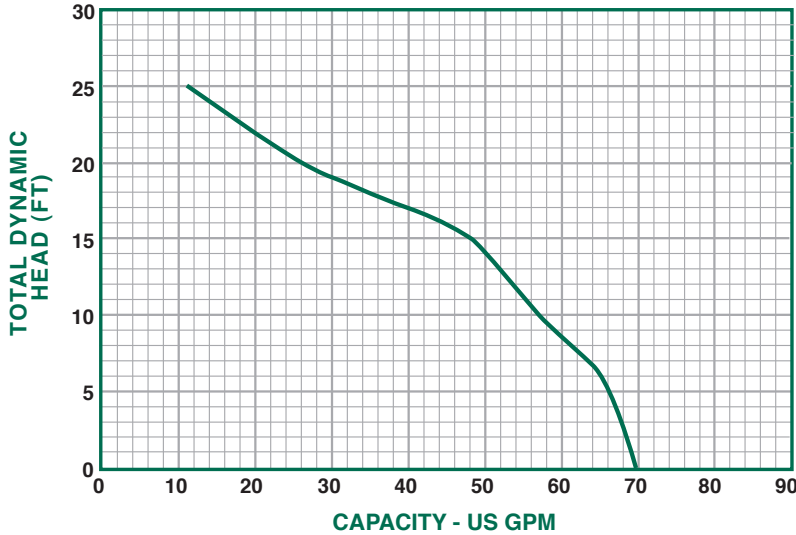

Performance

Model	Gallons per Minute in Feet					
5050CUEF	0	5	10	15	20	25
5050CTEF						
5050CTEF25	70	66	58	48	25	10

Specifications

Part No.	Model No.	HP	Volts	Hz	Amps	Construction	Discharge Size	Cord Length	Solids Handling	RPM	Phase	Wt.
6191-115	5050CUEF (NO SWITCH)	1/2	120	60	7.6	Cast Iron	1 1/2"	10'	5/8"	3450	1	24
6191-113	5050CTEF	1/2	120	60	7.6	Cast Iron	1 1/2"	10'	5/8"	3450	1	25
6191-117	5050CTEF25	1/2	120	60	7.6	Cast Iron	1 1/2"	25'	5/8"	3450	1	28

SUBMITTAL INFORMATION

- Split Capacitor Motor - 1/2 HP continuous duty, thermal protected
- Lifts water up to 25' of vertical height
- 10' power cord, 25' cords are also available for an additional charge
- Available with or without tethered switch
- Large 1 1/2" discharge for high capacity pumping
- Handles 5/8" solids
- Non clogging stainless steel vortex impeller



NO-LEAD: The weighted average of the wetted surface of this no-lead product contacted by consumable water contains less than one quarter of one percent (0.25%) lead.



A.Y. McDonald Mfg. Co.
4800 Chavenelle Rd
Dubuque, IA 52002

Toll Free: 1-800-292-2737
sales@aymcdonald.com
aymcdonald.com

A.Y. McDonald considers the information on this assembly drawing correct when published. Item and option availability, including specifications, are subject to change without notice.

Submitted by: