

SUBMITTAL DATA SHEET

Iron Body Gas Ball Valves with Lockwing -860

3/4 FNPT x 1 FNPT

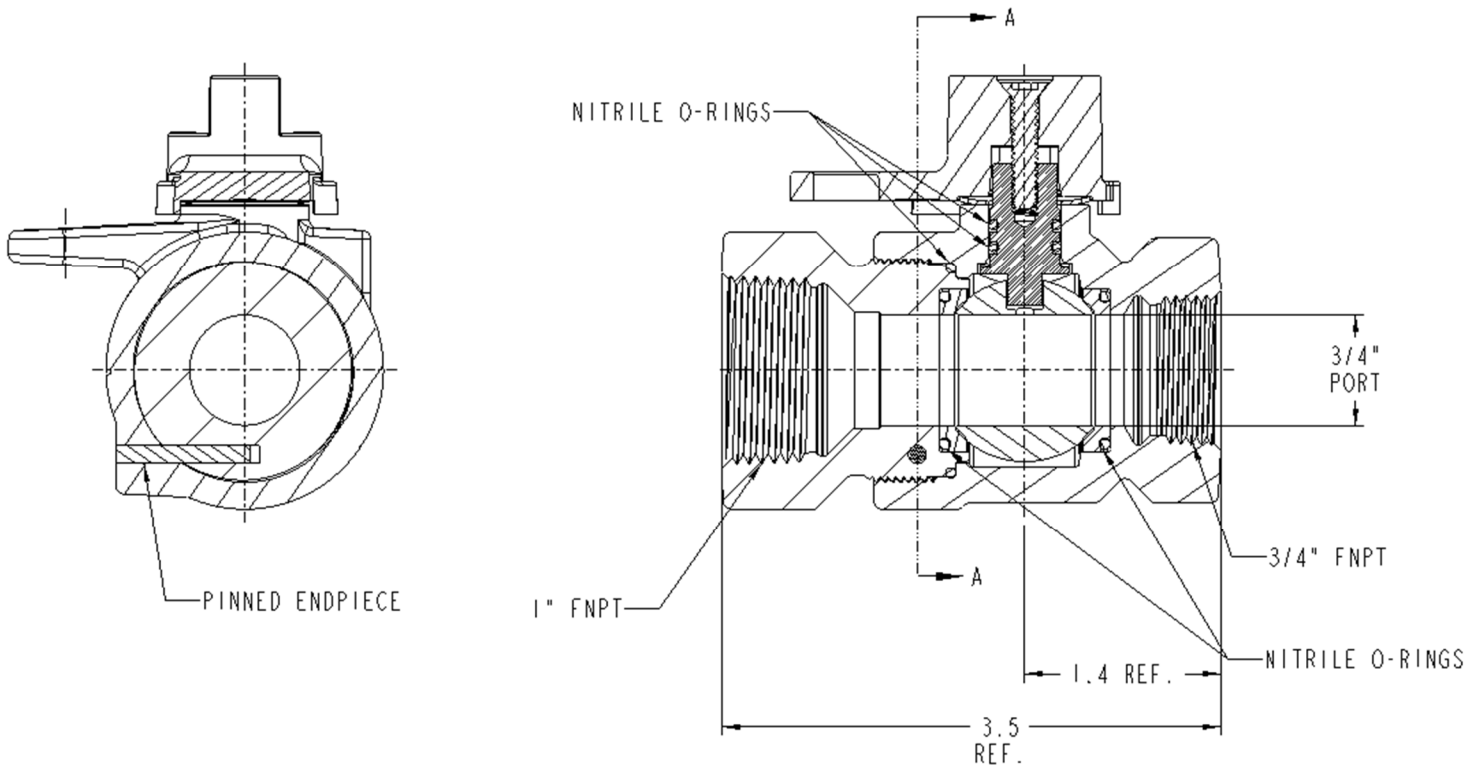

SUBMITTAL INFORMATION

- Manufactured in compliance with ANSI/ASME B16.33 (latest revision)
- Iron castings conform to ASTM A126 Class B Iron or Ductile Iron ASTM A536
- Optional Armorgalv® coating per ASTM A1059 (latest revision)
- UNS C36000 or CW617N brass ball rotates 360°
- Rated for 175 PSIG natural, manufactured, or LP gas pressure
- Blow out proof brass operating stem with two nitrile o-rings
- Tamper-resistant design prevents disassembly with normal household tools
- Full port opening sized to accommodate the best-known stop changers
- Lockwing design accommodates standard barrel locks
- Maintenance free design



A.Y. McDonald Mfg. Co.
4800 Chavenelle Rd
Dubuque, IA 52002

Toll Free: 1-800-292-2737
sales@aymcdonald.com
aymcdonald.com

A.Y. McDonald considers the information on this assembly drawing correct when published. Item and option availability, including specifications, are subject to change without notice.

Submitted by:

06-23