

# SUBMITTAL DATA SHEET

## Silicon Bronze Strap Saddle – 3825 9.05

Ductile Iron/Cement-Asbestos/Cast Iron - AWWA/CC



MODEL	SIZE	A	B	C	D	E	F
3825	9.05x3/4	3/4	3.19	3.19	1.69	HEX	9.05
3825	9.05x1	1	3.19	3.19	1.69	HEX	9.05
3825	9.05x1 1/2	1 1/2	3.19	4.19	3.10	OCT	9.05
3825	9.05x2	2	3.19	4.19	3.45	OCT	9.05

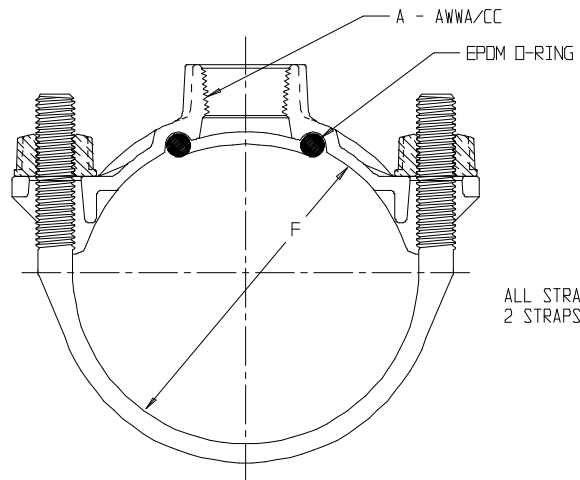
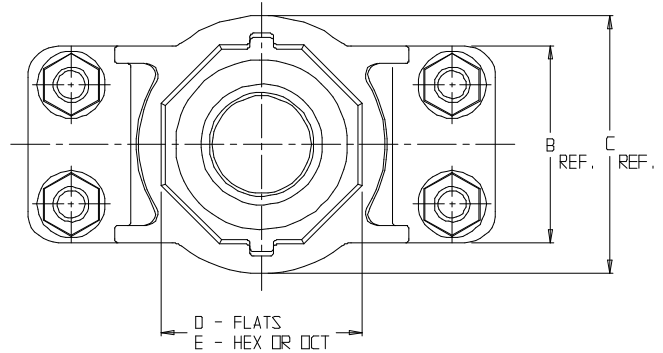

DRAWING MAY NOT RESEMBLE  
ACTUAL SADDLE CONFIGURATION

ALL STRAPS ARE .88 WIDE  
2 STRAPS PER ASSEMBLY

### SUBMITTAL INFORMATION

- Manufactured in compliance with ANSI/AWWA C800 (latest revision)
- Brass components conform to ASTM B62 and ASTM B584, UNS C83600 -85-5-5-5 (latest revision)
- Certified to NSF/ANSI 61
- Silicon Bronze strap(s) and cast brass nuts with enlarged washer bearing surface
- EPDM o-ring
- Pipe and tap size, and thread type identified on saddle
- Outlet boss with large wrench flats



**A.Y. McDonald Mfg. CO.**  
4800 Chavenelle Rd  
Dubuque, IA 52002

**Toll Free: 1-800-292-2737**  
sales@aymcdonald.com  
[aymcdonald.com](http://aymcdonald.com)

A.Y. McDonald considers the information on this assembly drawing correct when published. Item and option availability, including specifications, are subject to change without notice.

**Submitted by:**