

# SUBMITTAL DATA SHEET

## NL Ball Style Meter Stop – 74614BCS

FNPT x Oval Flange

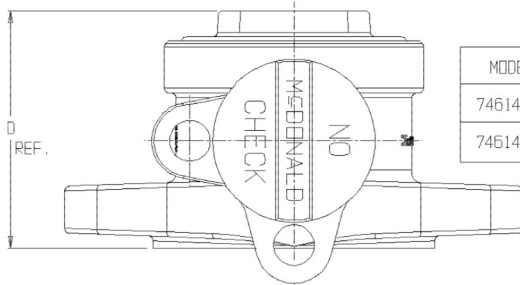

MODEL	SIZE	A	B	C	D	E	F	G	H
74614BCS	1 1/2	6.39	3.00	1.50	2.91	1.32	4.00	1 1/2	1 1/2
74614BCS	2	6.39	3.00	1.50	3.11	1.52	4.50*	2	1 1/2 OR 2

\* FLANGE FACE ALSO DRILLED FOR 1 1/2" METER WITH 4.00 SPACING

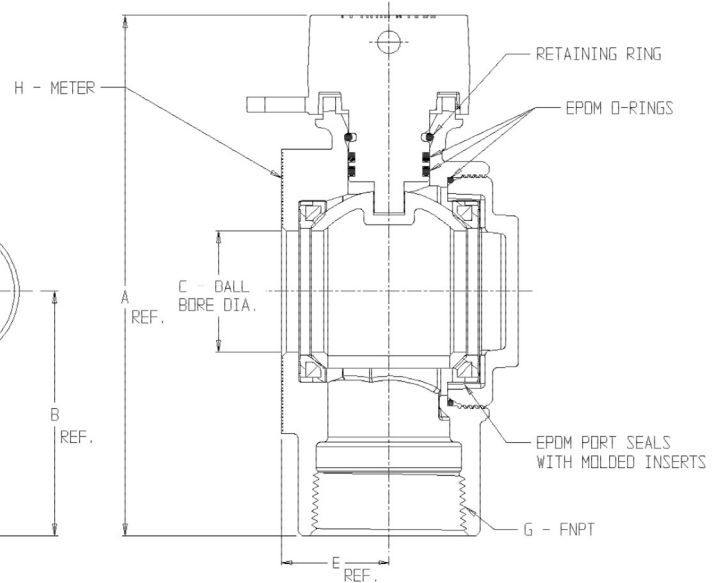
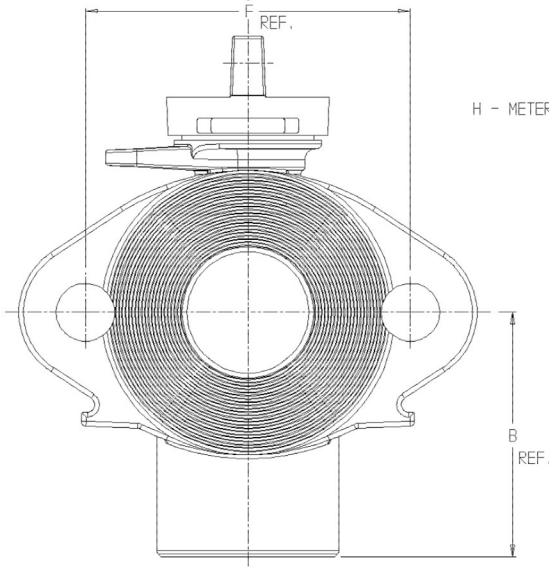

### SUBMITTAL INFORMATION

- Manufactured in compliance with ANSI/AWWA C800 (latest revision)
- Brass components in contact with potable water conform to ASTM B584, UNS C89833 (latest revision) and identified with "NL"
- Certified to NSF/ANSI 61 and NSF/ANSI 372
- Brass components not in contact with potable water conform to ASTM B62 and ASTM B584, UNS C83600 -85-5-5-5 (latest revision)
- PTFE coated brass ball
- Valve rated for 300 PSIG water pressure, end connections not to exceed rated pipe pressures.
- Blow out proof EPDM port seals
- End piece joint sealed with an EPDM o-ring and thread locker



A.Y. McDonald Mfg. Co.  
4800 Chavenelle Rd  
Dubuque, IA 52002

Toll Free: 1-800-292-2737  
sales@aymcdonald.com  
[aymcdonald.com](http://aymcdonald.com)

A.Y. McDonald considers the information on this assembly drawing correct when published. Item and option availability, including specifications, are subject to change without notice.

Submitted by: