

SUBMITTAL DATA SHEET

Ductile Iron Saddle with Cor-Ten Steel Strap – 4815A

Ductile Iron/Cement-Asbestos/Cast Iron x AWWA/CC



MODEL	SIZE	A	B
4815A	4 X 3/4	3/4	4.50 - 4.80
4815A	4 X 1	1	4.50 - 4.80
4815A	4 X 1 1/4	1 1/4	4.50 - 4.80
4815A	4 X 1 1/2	1 1/2	4.50 - 4.80
4815A	4 X 2	2	4.50 - 4.80
4815A	6 X 3/4	3/4	6.63 - 6.90
4815A	6 X 1	1	6.63 - 6.90
4815A	6 X 1 1/4	1 1/4	6.63 - 6.90
4815A	6 X 1 1/2	1 1/2	6.63 - 6.90
4815A	6 X 2	2	6.63 - 6.90
4815A	8 X 3/4	3/4	8.63 - 9.05
4815A	8 X 1	1	8.63 - 9.05
4815A	8 X 1 1/4	1 1/4	8.63 - 9.05
4815A	8 X 1 1/2	1 1/2	8.63 - 9.05
4815A	8 X 2	2	8.63 - 9.05
4815A	10 X 3/4	3/4	10.75 - 11.10
4815A	10 X 1	1	10.75 - 11.10
4815A	10 X 1 1/4	1 1/4	10.75 - 11.10
4815A	10 X 1 1/2	1 1/2	10.75 - 11.10
4815A	10 X 2	2	10.75 - 11.10
4815A	12 X 3/4	3/4	12.75 - 13.20
4815A	12 X 1	1	12.75 - 13.20
4815A	12 X 1 1/4	1 1/4	12.75 - 13.20
4815A	12 X 1 1/2	1 1/2	12.75 - 13.20
4815A	12 X 2	2	12.75 - 13.20

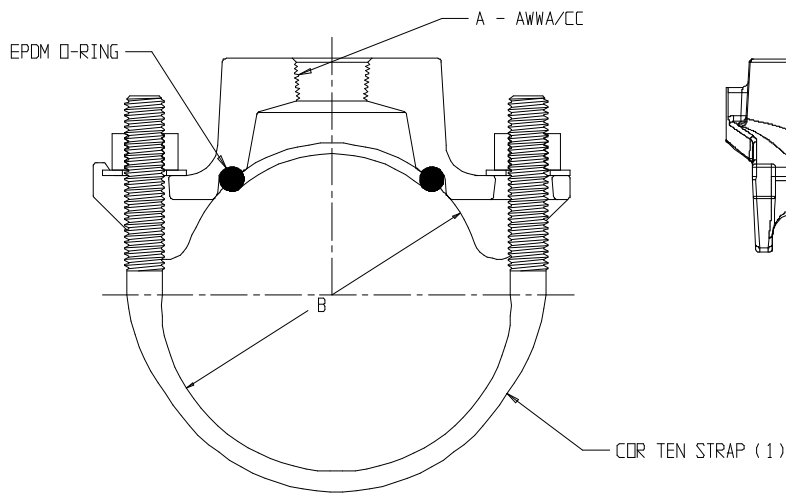
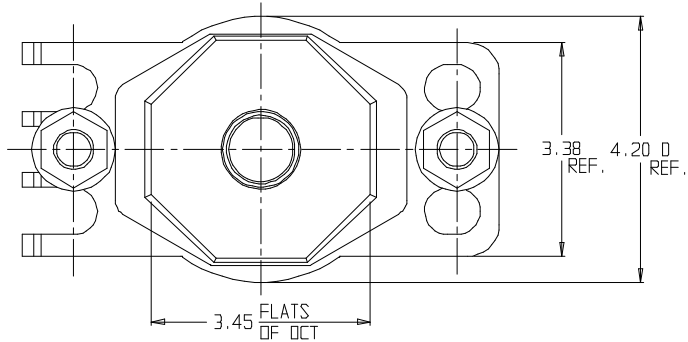

SUBMITTAL INFORMATION

- Manufactured in compliance with ANSI/AWWA C800 (latest revision)
- Ductile iron conforms to ASTM A536 class 65-45-12 (latest revision) epoxy coated
- Certified to NSF/ANSI 61
- Zinc plated Cor-Ten steel strap(s). Stainless steel nuts (PTFE coated) and washers
- EPDM o-ring
- Pipe and tap size, and thread type identified on saddle
- Outlet boss with large wrench flats
- Powder coated with blue epoxy



A.Y. McDonald Mfg. CO.
4800 Chavenelle Rd
Dubuque, IA 52002

Toll Free: 1-800-292-2737
sales@aymcdonald.com
aymcdonald.com

A.Y. McDonald considers the information on this assembly drawing correct when published. Item and option availability, including specifications, are subject to change without notice.

Submitted by: