

# SUBMITTAL DATA SHEET

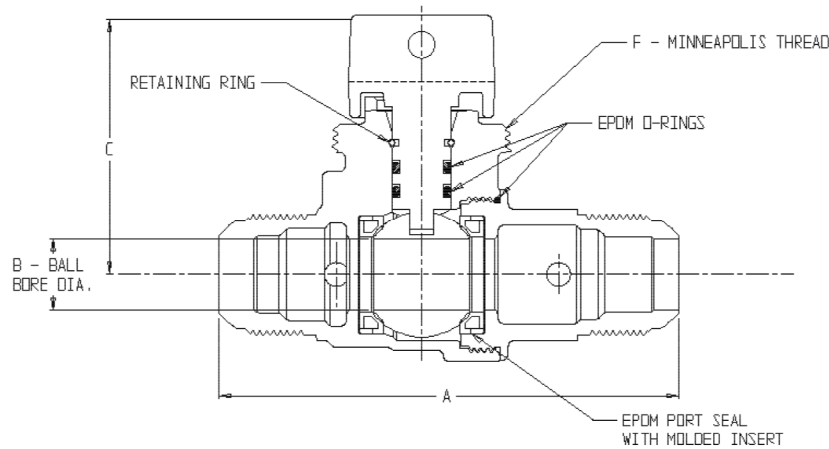

## NL Ball Style Curb Stop – 76104L

Flare x Flare



MODEL	SIZE	A	B	C	D	F
76104L	3/4	4.81	.75	2.68	3/4	1 1/2
76104L	1 X 3/4 X 3/4	4.92	.75	2.68	1	1 1/2
76104L	1 X 3/4 X 1	4.86	.75	2.68	1	1 1/2
76104L	1	5.48	1.00	2.65	1	1 1/2
76104L	1 1/4 X 1 X 1	5.75	1.00	2.65	1 1/4	1 1/2
76104L	1 1/4 X 1 X 1 1/4	6.34	1.00	2.65	1 1/4	1 1/2
76104L	1 1/4	6.50	1.25	2.94	1 1/4	2
76104L	1 1/2	6.84	1.50	3.41	1 1/2	2
76104L	2	8.76	2.00	3.67	2	2

### SUBMITTAL INFORMATION

- Manufactured in compliance with ANSI/AWWA C800 (latest revision)
- Brass components in contact with potable water conform to ASTM B584, UNS C89833 (latest revision) and identified with “NL”
- Certified to NSF/ANSI 61 and NSF/ANSI 372
- Brass components not in contact with potable water conform to ASTM B62 and ASTM B584, UNS C83600 -85-5-5-5 (latest revision)
- PTFE coated brass ball
- Valve rated for 300 PSIG water pressure, end connections not to exceed rated pipe pressures.
- Blow out proof EPDM port seals
- End piece joint sealed with an EPDM o-ring and thread locker



**A.Y. McDonald Mfg. Co.**  
4800 Chavenelle Rd  
Dubuque, IA 52002

**Toll Free: 1-800-292-2737**  
sales@aymcdonald.com  
[aymcdonald.com](http://aymcdonald.com)

A.Y. McDonald considers the information on this assembly drawing correct when published. Item and option availability, including specifications, are subject to change without notice.

**Submitted by:**