

SUBMITTAL DATA SHEET

SS Strap Saddle – 3845F

C900 PVC x AWWA/CC



MODEL	SIZE	A	B	C	D	E	F	G
3845F	4 X 3/4	3/4 AWWA/CC	3.19	3.19	1.69	HEX	4.74 - 5.40	3.00
3845F	4 X 1	1 AWWA/CC	3.19	3.19	1.69	HEX	4.74 - 5.40	3.00
3845F	4 X 1 1/2	1 1/2 AWWA/CC	3.19	4.19	3.10	OCT	4.74 - 5.40	3.00
3845F	4 X 2	2 AWWA/CC	3.19	4.19	3.45	OCT	4.74 - 5.40	3.00
3845F	6 X 3/4	3/4 AWWA/CC	3.19	3.19	1.69	HEX	6.84 - 7.50	3.00
3845F	6 X 1	1 AWWA/CC	3.19	3.19	1.69	HEX	6.84 - 7.50	3.00
3845F	6 X 1 1/2	1 1/2 AWWA/CC	3.19	4.19	3.10	OCT	6.84 - 7.50	3.00
3845F	6 X 2	2 AWWA/CC	3.19	4.19	3.45	OCT	6.84 - 7.50	3.00
3845F	8 X 3/4	3/4 AWWA/CC	3.19	3.19	1.69	HEX	8.99 - 9.67	3.00
3845F	8 X 1	1 AWWA/CC	3.19	3.19	1.69	HEX	8.99 - 9.67	3.00
3845F	8 X 1 1/2	1 1/2 AWWA/CC	3.19	4.19	3.10	OCT	8.99 - 9.67	3.00
3845F	8 X 2	2 AWWA/CC	3.19	4.19	3.45	OCT	8.99 - 9.67	3.00
3845F	10 X 3/4	3/4 AWWA/CC	3.19	3.19	1.69	HEX	11.04 - 12.12	3.00
3845F	10 X 1	1 AWWA/CC	3.19	3.19	1.69	HEX	11.04 - 12.12	3.00
3845F	10 X 1 1/2	1 1/2 AWWA/CC	3.19	4.19	3.10	OCT	11.04 - 12.12	3.00
3845F	10 X 2	2 AWWA/CC	3.19	4.19	3.45	OCT	11.04 - 12.12	3.00
3845F	12 X 3/4	3/4 AWWA/CC	3.19	3.19	1.69	HEX	13.14 - 14.58	3.00
3845F	12 X 1	1 AWWA/CC	3.19	3.19	1.69	HEX	13.14 - 14.58	3.00
3845F	12 X 1 1/2	1 1/2 AWWA/CC	3.19	4.19	3.10	OCT	13.14 - 14.58	3.00
3845F	12 X 2	2 AWWA/CC	3.19	4.19	3.45	OCT	13.14 - 14.58	3.00

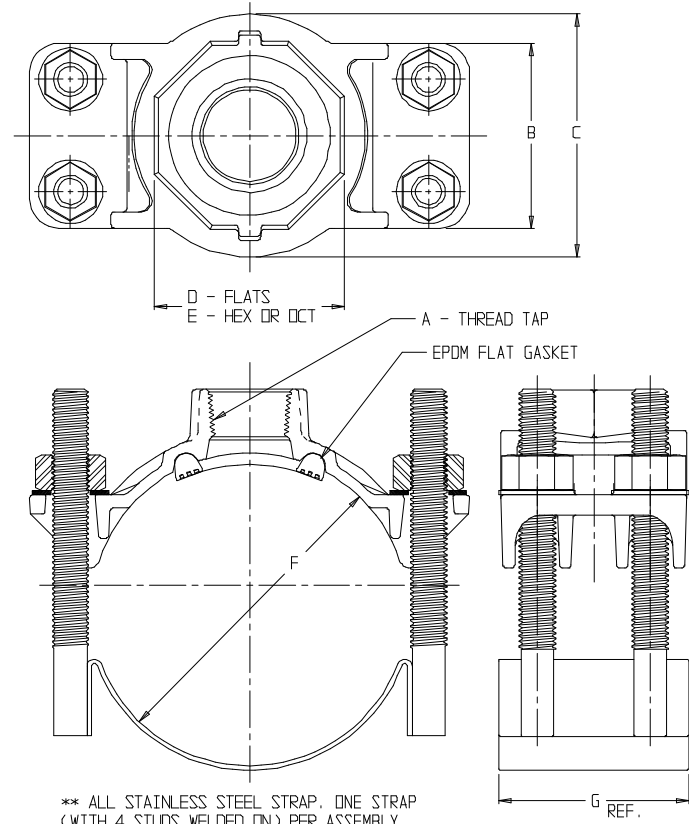

DRAWING MAY NOT RESEMBLE
ACTUAL SADDLE CONFIGURATION

SUBMITTAL INFORMATION

- Manufactured in compliance with ANSI/AWWA C800 (latest revision)
- Brass components conform to ASTM B62 and ASTM B584, UNS C83600 -85-5-5-5 (latest revision)
- Certified to NSF/ANSI 61
- 304L Stainless Steel strap(s) and 5/8" studs. Stainless steel nuts (PTFE coated) and washers
- EPDM flat gasket
- Pipe and tap size, and thread type identified on saddle
- Outlet boss with large wrench flats



A.Y. McDonald Mfg. CO.
4800 Chavenelle Rd
Dubuque, IA 52002

Toll Free: 1-800-292-2737
sales@aymcdonald.com
aymcdonald.com

A.Y. McDonald considers the information on this assembly drawing correct when published. Item and option availability, including specifications, are subject to change without notice.

Submitted by: